

TECHNICAL MANUAL

OPERATOR, UNIT, INTERMEDIATE DIRECT SUPPORT

MAINTENANCE MANUAL

(INCLUDING REPAIR PARTS AND SPECIAL TOOLS LIST)

FOR

50, 000 GALLON CAPACITY

DRINKING WATER TANK,

ASSEMBLY, FABRIC, COLLAPSIBLE

NSN 5430-01-1 06-9677

**HEADQUARTERS, DEPARTMENT OF THE ARMY
14 MAY 1987**

CHANGE
NO. 1

HEADQUARTERS
DEPARTMENT OF THE ARMY
WASHINGTON, D C, 9 SEPTEMBER 1992

Operator, Unit, Intermediate Direct Support
Maintenance Manual
(Including Repair Parts and Special Tools List)
for

**50, 000 GALLON CAPACITY
DRINKING WATER TANK ASSEMBLY,
FABRIC, COLLAPSIBLE
NSN 543001-1069677**

Approved for public release, Distribution is unlimited

TM 5-5430-217-13&P, 14 May 1987 is changed as follows:

1. Remove and insert pages as indicated below New or changed text material s indicated by a vertical bar in the margin An illustration change is indicated by a miniature pointing hand.

Remove pages

i and ii
47 and 48
69

Insert pages

i and ii
47 and 48
69 and 70

2. Retain this sheet in front of manual for reference purposes

By Order of the Secretary of the Army:

GORDON R. SULLIVAN
General, United States Army
Chief of Staff

Official:

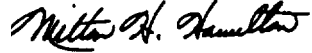

MILTON H. HAMILTON
Administrative Assistant to the
Secretary of the Army
02401

DISTRIBUTION:

To be distributed in accordance with DA Form 12-25-E, block 3828,
Operator, Unit and Direct support Maintenance requirements for

CONTENTS
COMMERCIAL MANUAL
50, 000 GALLON COLLAPSIBLE, TANK, ASSEMBLY, FABRIC
DRINKING WATER

	<u>Page Number</u>
1.0 <u>Scope</u>	1
2.0 <u>General Description</u>	1 - 4
2.1 Identification Markings	4 - 5
3.0 <u>Installation Instruction</u>	5
3.1 Selection of Site and Preparation	5 - 6
3.2 Layout of Tank	6 - 7
3.3 Assembly of Components	7 - 8
3.4 Containment	8
4.0 <u>Operation Instruction</u>	8
4.1 Before Filling Operation Inspection	8
4.2 During Liquid Storage Inspection	9
4.3 Filling Tank	9 - 10
4.4 Draining Tank	10
4.5 Utility	10 - 11
4.6 Storage and Repackaging Instructions	11 - 12
4.7 Cleaning, Folding and Rolling Tank for Storage	12 - 13
5.0 <u>Maintenance Instruction</u>	13
5.1 Lubrication and Cleaning	13 - 14
5.2 Preventive Maintenance	14 - 16
5.3 Troubleshooting	17 - 21
5.4 Corrective Maintenance	21 - 37
6.0 <u>Preparation for Re-shipment and Storage</u>	38
6.1 Removing Tank from Service	38
6.2 Storage	38

APPENDIX

	<u>Page Number</u>
A - References	39
B - Maintenance Allocation Chart	40 - 47
C - Repair Parts and Special Tools List	48 - 64
D - Components of End Item and Basic Issue Items List	65 - 69
■ E - Expendable/Durable Supplies and Materials List	70

Change 1 ii

COMMERCIAL MANUAL
50, 000 GALLON COLLAPSIBLE, TANK, ASSEMBLY, FABRIC
DRINKING WATER

1.0 Scope

1.0.1 This manual covers the information and instructions necessary for the installation, operation, maintenance, repacking and repairs for 50, 000 gallon capacity Collapsible Drinking Water Storage Tank, with filling and emergency repair items.

1.0.2 Personnel who are required to understand the operation and service of collapsible storage tanks should read and be familiar with the information contained in this manual.

2.0 General Description

2.0.1 The collapsible tank is intended for the storage of only drinking water.

2.0.2 The tank is constructed of a reinforcing fabric impregnated with an elastomeric coating.

2.0.3 The tank when filled assumes a pillow shape with the length and width reducing from flat dimensions approximately one foot each and expanding in height four to five feet. The maximum height stenciled on tank must be observed to avoid overfilling.

2.0.4 Handles are provided along the sides and ends of the tank to permit lifting and positioning of the tank when empty.

2.0.5 A vent assembly is integral to the tank on top center of the tank. This assembly consists of:

1. Vent and drain fitting (integral with tank)
2. "Oil Ring gasket, rubber

2.0 General Description (continued)

2.0.5 (continued)

3. Washer, plain, 1/41" ID
4. Bolt, Hexagon Head, 1/4 - 20 UNC 1.25" long
5. Coupling half, quick disconnect cam locking type, male, flanged
6. Coupling half, quick disconnect, cam locking V type, female, threaded
7. Dust cap with 6" long security chain Style B
8. Pipe, 2" x 10" Schedule 40
9. Relief cap with gasket
10. Gasket - coupling half, 2" size, rubber

2.0.6 There are two filler/discharge/manhole fittings. These are located on opposite ends and sides on the top of the tank. This assembly consists of:

1. Access door fitting (integral with tank)
2. Suction stub 4"
3. "O" Ring gasket (rubber)
4. Oval closure plate
5. Gasket (cork composition)
6. Coupling half flanged, 4" size
7. Elbow female to male 4" 90° elbow
8. Dust cap 4" with gasket and security chain
9. Bolt Hex Head .375" - 16UNCX 1.5" long
10. Bolt Hex Head .250" - 20 UNC x 1.00" long
11. Washer, plain 1/4" ID
12. Washer, lock helical .375" size

2.0 General Description (continued)

2.0.6 (continued)

13. Nut, Hex mach screw .375" - 16UNC
14. Elbow female to female 4" x 90° size
15. Gasket - coupling half, 4" size (rubber)
16. Thread seal 3/8"

2.0.7 The drain assembly fitting is located on the bottom side at the end of the tank adjacent to one manhole fitting in the same panel as the other manhole fitting.

This assembly consists of:

1. Vent and drain fitting (integral with tank)
2. Drain fitting
3. Plug and chain
4. Ring gasket (rubber)
5. Bolt, Hexagon Head 1/4" - 20 UNC 1.00" long
6. Washer, plain, 1/4" ID

2.0.8 The hose assembly is attached to the drain fitting located on the bottom of the tank and has a male fitting to attach the gate valve on the opposite end from the tank.

The hose assembly consists of:

1. 3/4" suction hose 8' long with male fitting on both ends with 1/2" NPT threaded and banded shank
2. Gate valve size 1/2 inch, 125 psi pressure class

2.0.9 The repair kit consists of three different sizes of sealing clamps and two different sizes of wooden plugs and are provided for the purpose of repairing minor holes,

2.0 General Description (continued)

2.0.9 (continued)

cuts or tears that may occur in the tank wall. This Repair Kit consists of:

1. 3" sealing clamp
2. 5" sealing clamp
3. 7-1/2" sealing clamp
4. 3" wooden plug
5. 5" wooden plug
6. Repair Instructions
7. "O" Ring (access fitting)
8. "O" Ring (vent fitting)
9. Gasket 2" (vent fitting)
10. Gasket 4" (filler/discharge fitting)

2.0.10 Flat tank dimensions: 25.0 ft. width and length 65.0 ft. (minimum).

2.0.11 Tank shipping container Type II, Class C, Style C size 94" long x 46" wide x 45" high.

2.1 Identification Markings

Tank, Fabric, Collapsible

50, 000 gallons, Drinking Water

NSN: 5430-01-106-9677

Serial No.: (Specified each tank)

Mfr. American Fuel Cell and Coated Fabrics Company, Waldo Highway,

Magnolia, AR 71753

Weight Empty: 1640 lbs.

Contract No.: DAAK01-86-C-C025

2.1 Identification Markings (continued)

Lot: As applicable

Mfg. date: (Month and Year)

3.0 Installation Instructions

3.1 Selection of Site and Preparation

- 3.1.0 Select a site in proximity of intended usage approximately 6 feet wider and longer than the flat empty tank size. For best operating condition, the selected site should be level but should never exceed three inches slope in 100 ft.
- 3.1.1 If a level site cannot be obtained, the tank may be positioned with lengthwise axis parallel to the slight slope with drainage in downhill position.
- 3.1.2 In those instances when the tank is positioned across the slope, it is important that the tank be stabilized against rolling. This can be accomplished by forming an earthen dike on the downhill side, or by means of smooth timbers or sand bags. A level spot or depression may be cut into the hillside to level tank.
- 3.1.3 In site preparation, avoid deep irregularities which will trap liquid. Remove sharp, potentially damaging objects.

3.0 Installation Instructions (continued)

3.1 Selection of Site and Preparation (continued)

3.1.4 It is recommended that if at all possible, dikes should be constructed around the tank. These dikes can be earthen or whatever is available. However, they should be at least 3/4 of the tank filled height with a minimum of a 3 ft. base. The cross section of the dike would form a triangle with a minimum of 1.5:1 slope.

3.2 Layout of Tanks

3.2.1 Position packaged tank on site and proceed with unpacking taking care not to damage tank with sharp objects, tools or with packing box nails.

3.2.2 Remove tank from shipping container, unfold and center in the prepared site. Remove all pressure sensitive tape or other covering from fitting areas and inspect. Visual inspection of all fittings should be made to insure all sealing surfaces are free of contamination. Use caution to prevent foreign materials from entering the fitting openings. Visually inspect vent and filler/discharge covers for cleanliness and proper sealing of "O" rings. Assemble the items and secure to tank, following the recommended torque rates stencil the tank.

3.0 Installation Instructions (continued)

3.2 Layout of Tanks(continued)

3.2.3 Inspect visually the tank, laid out on the ground, for cuts, abrasions or other damages. Report any damage or missing parts.

Caution: Handles are for moving and positioning the tank while empty only.

3.2.4 Remove all the accessories from the accessory box, inspect and prepare for assembly.

Reference Appendix C.

3.2.5 Remove the repair kit, open and inspect items against the listing of items. Repack and place in safe storage area. Do not open overpack kit box as these items are for long term storage.

Level A Reference Appendix C, C-9 and C-10.

3.3 Assembly of Components

3.3.1 Attachments: Assemble heavy attachments together prior to assembly onto tank. Avoid heavy twisting of fittings and/or tank wall.

3.3.2 Use of anti-sizing pipe joining compound is recommended where threads are involved.

3.3.3 Assembly of all components should be made prior to the attachment to the tank.

3.3.4 The assembly of the drain to insure complete drainage may necessitate the use of an elbow with pipe and valve on drain fitting. Turn the corner of the tank back with the drain fitting

3.0 Installation Instructions (continued)

3.3 Assembly of Components (continued)

3.3.4 (continued)

exposed and excavate a shallow trench underneath drain fitting to facilitate draining and reposition of tank and fitting.

3.4 Containment

This collapsible tank is manufactured for the use of only drinking water.

4.0 Operation Instructions

4.1 Before Filling Operation Inspection

4.1.1 See that location site is free from all debris that may damage the tank.

4.1.2 Check to assure that tank is on level ground or that tank is placed on site in accordance with instructions in Paragraph 3.1 "Installation" to assure that filled tank will not roll. This operation is accomplished prior to filling of tank.

4.1.3 Check all connections and fittings to see that they are properly secured with torque not to exceed recommended values stenciled on the tank.

4.1.4 Before filling check all connections to see that they are tight and leak proof and that proper attachments for all auxiliary equipment have been made.

4.0 Operation Instructions (continued)

4.2 During Liquid Storage Inspection

4.2.1 Frequent and regular inspection of tank to detect any evidence of leakage will permit repairs while damaged area is small in size.

4.2.2 Frequent and regular inspection will prevent the accumulations of debris that may damage the tank.

4.3 Filling Tank

4.3.1 Attach supply line to tank. Check the vent fitting installation to be sure that the cap is not plugged then fill to noted capacity.

4.3.2 Observe tank body, fittings, and vent during filling operations to assure that they are secure and do not leak.

Caution: Do not exceed the noted capacity of the tank when filling.

Note: If metering gauge is not available at the time of filling, do not exceed the recommended maximum filled height of 5.00 ft.

4.3.3 With all plumbing attached, liquid may be introduced into the container by several means. Two recommended methods are:

- a. With the standpipe in place and vent relief valve open water may be introduced into the tank through the filler/discharge fitting until the fluid reaches

4.0 Operation Instructions (continued)

4.3 Filling Tank (continued)

4.3.3 (continued)

a. (continued)

the specified head in the tank standpipe of 3.0 inches, but not, to exceed maximum filled height.

Note Paragraph 4.3.2.

b. With vent closed, liquid may be metered into collapsed tank through the filler/discharge fitting by means of a gravity head or by pumping.

4.4 Draining Tank

4.4.1 Water may be withdrawn partially or completely from the tank with or without the tank vent open, since the tank collapses concurrently with the withdrawal of the water.

4.4.2 The tank when drained will assume a relatively flat position. However, in order to completely empty tank in preparation for repacking and storage lift the tank end, by using handles, opposite the drain fitting, in order to force any lingering water toward and out the drain fitting.

4.5 Utility

This tank contains a construction for potable (drinking) water and is suitable for dormant storage from 160⁰F to minus 300F. The tanks and components shall be suitable

4.0 Operation Instructions (continued)

4.5 Utility (continued)

for operational use at ambient temperatures from 125°F to minus 250°F.

Note & Caution: Amfuel^(R) does not recommend the use of the tank filled with water below freezing (32°F). If the tank is used in temperatures below freezing, caution must be used not to allow the water in the tank or in contact with accessories to freeze as damage will occur to both tank and accessories.

4.6 Storage and Repackaging Instructions

4.6.1 Tank Preparation for Storage

4.6.1.1 Remove all liquid as described in Paragraph 4.4 this manual.

4.6.1.2 Replace drain fitting plugs after completely emptying tank through drain fitting.

4.6.1.3 The following procedure should be followed whenever possible before storing the tank.

- a. Disconnect hose assembly from filler/discharge, manhole fittings, if applicable.
- b. Insert air hose through adapter on manhole cover plate (block off so air cannot escape).

4.0 Operation Instructions (continued)

4.6 Storage and Repackaging Instructions (continued)

4.6.1 Tank Preparation for Storage (continued)

4.6.1.3 (continued)

- c. Inflate tank to no more than three feet in height with air allowing air to escape through vent assembly.

Caution: Do not over inflate tank.

- d. Tank should be aired in this manner for approximately ½ hour or until all liquid has evaporated.
- e. Shut off air, remove air hose and let tank deflate.
- f. Remove standpipe from vent fitting.
- g. Install dust cap on manhole cover plate (if applicable). All tank openings should be covered with caps or protective covering to keep clean.

4.7 Cleaning, Folding and Rolling Tank for Storage

- 4.7.1 Place hose vent assemblies on ground at end opposite filler/discharge/manhole fitting. All auxiliary and accessory hardware is to be repacked into hardware shipping container.

4.0 Operation Instructions (continued)

4.7 Cleaning, Folding and Rolling Tank for Storage (continued)

4.7.2 Fold sides of tank towards longitudinal center line so that the two sides will meet at the center line until folded width is approximately 6 feet.

4.7.3 Fold and begin rolling tank toward filler/discharge/manhole fitting.

4.7.4 Clean and brush off all stones and miscellaneous debris that may be picked up from the ground.

4.7.5 Care should be taken not to damage tank by rough handling or careless storage. In the event a metal clamp repair has been made, avoid folding the tank in such a manner as to cause damage to the tank.

4.7.6 Repack and store accessories and auxiliary equipment in box.

When tank is not in use for any length of time, it is important that it be stored under a cover or in a container so as to be out of the direct exposure to sunlight. In this manner optimum life may be realized.

5.0 Maintenance Instructions

5.1 Lubrication and Cleaning

5.1.1 Lubrication. There is no lubrication required for the 50, 000 gallon collapsible water tank.

5.1.2 Exterior Cleaning. Dirt on the tank and tank accessories should be flushed off with water.

5.0 Maintenance Instructions (continued)

5.1 Lubrication and Cleaning (continued)

5.1.3 Interior Cleaning. The interior of the tank requires little cleaning if it is used for the same commodity. If cleaning is required, fill the tank with approximately 150 gallons of a mild detergent/water solution. Close off all openings and slish the detergent solution back and forth by alternately pulling the ends of the tank over the top of the tank. Drain the solution from the tank and flush with clean water. Repeat flushing as necessary. Dry the inside of the tank with a large volume air blower if the tank is to be placed in dry storage.

5.2 Preventive Maintenance

5.2.1 Inspection. The tank will be inspected weekly to ensure that the equipment is ready for operation at all times. Through regular inspection, defects can be found and corrected before serious damage occurs. Defects found during operation should be noted and corrected as soon as servicing operations have stopped. Refer to Table III for inspection procedures.

5.0 Maintenance Instructions (continued)

5.2 Preventive Maintenance (continued)

Table III. Inspection Procedures

<u>Item No.</u>	<u>Items To Be Inspected</u>	<u>Procedures</u>
1	Installation area	Inspect installation area. Remove sharp objects that might cause punctures or leaks.
2	Tank Envelope	Inspect tank envelope for tears, punctures and leaks. Refer to Paragraph 5.4.2 for maintenance procedures.
3	Vent assembly	Inspect vent assembly for damage or leakage. Inspect relief valve for freedom of operation. Refer to Paragraph
4	Filler assembly	Inspect filler assembly for damage or leakage. Inspect gaskets for damage. Refer to Paragraph 5.4.4 for maintenance procedures.

5.0 Maintenance Instructions (continued)

5.2 Preventive Maintenance (continued)

Table III. Inspection Procedures (continued)

<u>Item No.</u>	<u>Items To Be Inspected</u>	<u>Procedures</u>
5	Discharge assembly	Inspect discharge assembly for damage or leakage. Refer to Paragraph 5.4.4 for maintenance procedures.
6	Drain assembly	Inspect drain valve and hose for leakage. Refer to Paragraph 5.4.5 for maint- enance procedures.
7	Filler/Discharge Valve assembly, 4"	Inspect parts for leakage. Inspect gaskets for damage. Refer to Paragraph 5.4.6 for maintenance procedures.
8	Hose assembly	Inspect hoses for leakage. Inspect hose connections for leakage. Refer to Paragraph 5.4.7 for maintenance pro- cedures.

5.0 Maintenance Instructions (continued)

5.3 Troubleshooting

5.3.1 This section contains troubleshooting information for locating and correcting most operating problems. Each malfunction for an individual component, unit or system is followed by a list of tests or inspections which help you determine probable cause and corrective actions to take. You should perform the tests/inspections and corrective actions in the order listed. This manual cannot list all malfunctions that may occur, nor all tests or inspections and corrective actions. If a malfunction is not listed or is not corrected by listed corrective actions, notify your supervisor.

5.3.2 Troubleshooting. For troubleshooting, refer to Table IV.

Note: Although the 4" hose is not considered to be part of the 50, 000 gallon water tank, it is necessary for the proper functioning of the tank; and, therefore, has been included in the following Troubleshooting and Maintenance procedures.

5.0 Maintenance Instructions (continued)

5.3 Troubleshooting (continued)

5.3.2 (continued)

Table IV. Troubleshooting

<u>Malfunction</u>	<u>Test or Inspection</u>	<u>Corrective Action</u>
1. Tank leaks	- Check tanks for punctures or cuts	- Repair puncture with sealing clamps or plugs (Ref. Paragraph 5.4.2).
2. Vent assembly	- Check "O" Ring between flanged adapter and tank for nicks, or distortion. - Check vent stand pipe for cracks or damage. - Check coupling for breaks or cracks. - Check for loose or missing hexagon head bolts.	- Remove coupling from tank fitting and replace "O" (Ref. Paragraph 5.4.3). - Remove and replace vent stand pipe (Ref. Paragraph 5.4.3). - Remove and replace coupling (Reference Paragraph 5.4.3). - Tighten or replace bolts.
3. Pressure Relief Valve remains open	- Check relief valve for debris in tube or on pivot pin.	- Clean relief valve (Ref. Paragraph 5.4.3).

5.0 Maintenance Instructions (continued)

5.3 Troubleshooting (continued)

5.3.2 (continued)

Table IV. Troubleshooting (continued)

<u>Malfunction</u>	<u>Test or Inspection</u>	<u>Corrective Action</u>
4. Hose Assembly leaks	<ul style="list-style-type: none">- Check female coupling gaskets for damage or wear.- Check couplings on hose for dirt, damage or wear.- Check hose for cuts, breaks or leaks.	<ul style="list-style-type: none">- Remove and replace gaskets.- Remove dirt or any foreign objects inside couplings.- If leak continues, replace hose assembly.- If hose has cuts, breaks, or leaks, remove and replace hose assembly.
5. Filler Assembly leaks	<ul style="list-style-type: none">- Check for loose or missing hexagon head- Check "O" Ring between closure plate and tank fitting for nicks, breaks and distortion.- Check gaskets on either side of closure plate for damage or breaks.	<ul style="list-style-type: none">- Tighten or replace bolts as necessary.- Replace "O" Ring (Ref. Paragraph 5.4.4).- Replace gaskets (Ref. Paragraph 5.4.4).

5.0 Maintenance Instructions (continued)

5.3 Troubleshooting (continued)

Table IV. Troubleshooting (continued)

<u>Malfunction</u>	<u>Test or Inspection</u>	<u>Corrective Action</u>
6. Discharge Assembly leaks	- Check for loose or missing hexagon head bolts.	- Tighten or replace bolts as necessary.
	- Check "O" Ring between closure plate and tank fitting for nicks, breaks and distortion.	- Replace "O" Ring (Ref. Paragraph 5.4.4).
	- Check gaskets on either side of closure plate for damage or breaks.	- Replace gaskets (Ref. Paragraph 5.4.4).
7. Drain Assembly leaks	- Check for loose or missing hexagon head bolts.	- Tighten or replace bolts as necessary.
	- Check "O" Ring between drain fitting and tank metal face for nicks, breaks and distortion.	- Remove and replace "O" Ring (Ref. Paragraph 5.4.5).

5.0 Maintenance Instructions (continued)

5.3 Troubleshooting (continued)

Table IV. Troubleshooting (continued)

<u>Malfunction</u>	<u>Test or Inspection</u>	<u>Corrective Action</u>
8. Gate Valve Assembly leaking	- Check for loose or missing hexagon head bolts and nuts.	- Tighten or replace nuts and bolts as necessary.
	- Check for loose valve stem B-Nut.	- Tighten B-Nut.
	- Check female coupling gaskets for damage or wear.	- Remove and replace gaskets (Ref. Paragraph 5.4.6).
	- Check male coupling for dirt, damage or wear.	- Remove dirt or foreign objects from coupling. If leak continues, replace male coupling.

5.4 Corrective Maintenance

- 5.4.1 General. This section contains disassembly, repair and replace, and reassembly instructions for the tank.
- 5.4.2 Emergency Repairs to Tank Envelope. There are two ways to repair the tank envelope. Wooden plugs should be used as an immediate repair to stop the flow of water from the tank until it is possible to install a sealing clamp. Replacement may not be possible until the water

5.0 Maintenance Instructions (continued)

5.4 Corrective Maintenance (continued)

5.4.2 (continued) height and internal pressure of the tank have been reduced by discharging or draining water. Plugs can be used for tears up to 1-1/2 inches (3.81 centimeters). Sealing clamps can be used for tears up to six inches (15.24 centimeters).

a. Repairs with Wooden Plugs.

(1) Insert small end of plug into puncture. Turn clockwise until leak stops or slows.

(2) Remove plug and install clamp when operation permits.

b. Repairs with Sealing Clamps (See Figure V)

(1) Select proper size clamp using these guidelines for tears:

less than 2 inch (5.08 centimeter) -

use 3 inch clamp,

2 to 4 inch (5.08 to 10.16 centimeter) -

use 5 inch clamp,

4 to 6 inch (10.16 to 15.24 centimeter) -

use 7-1/2 inch clamp.

5.0 Maintenance Instructions (continued)

5.4 Corrective Maintenance (continued)

5.4.2 (continued)

b. (continued)

CAUTION: Use extreme care when enlarging a tear. Tension in the fabric may cause the fabric to rip further. Ideally, tank height should not be greater than two feet (0.61 meters) when you make this type repair.

- (2) Loop cord at top of clamp around wrist to prevent loss of clamp into tank.
- (3) Slip bottom half of clamp inside tank. If tear is too small for clamp to slip through, use a pocket knife to enlarge tear to accommodate width of clamp.
- (4) Rotate clamp so that its length runs with tear. Pull bottom half of clamp up against fabric. Slide top half down and over stud.
- (5) Tighten wing nut by hand until leak stops. If more tightening is necessary, use pliers. Do not overtighten.

5.4.2 Emergency Repairs to Tank Envelope (continued)

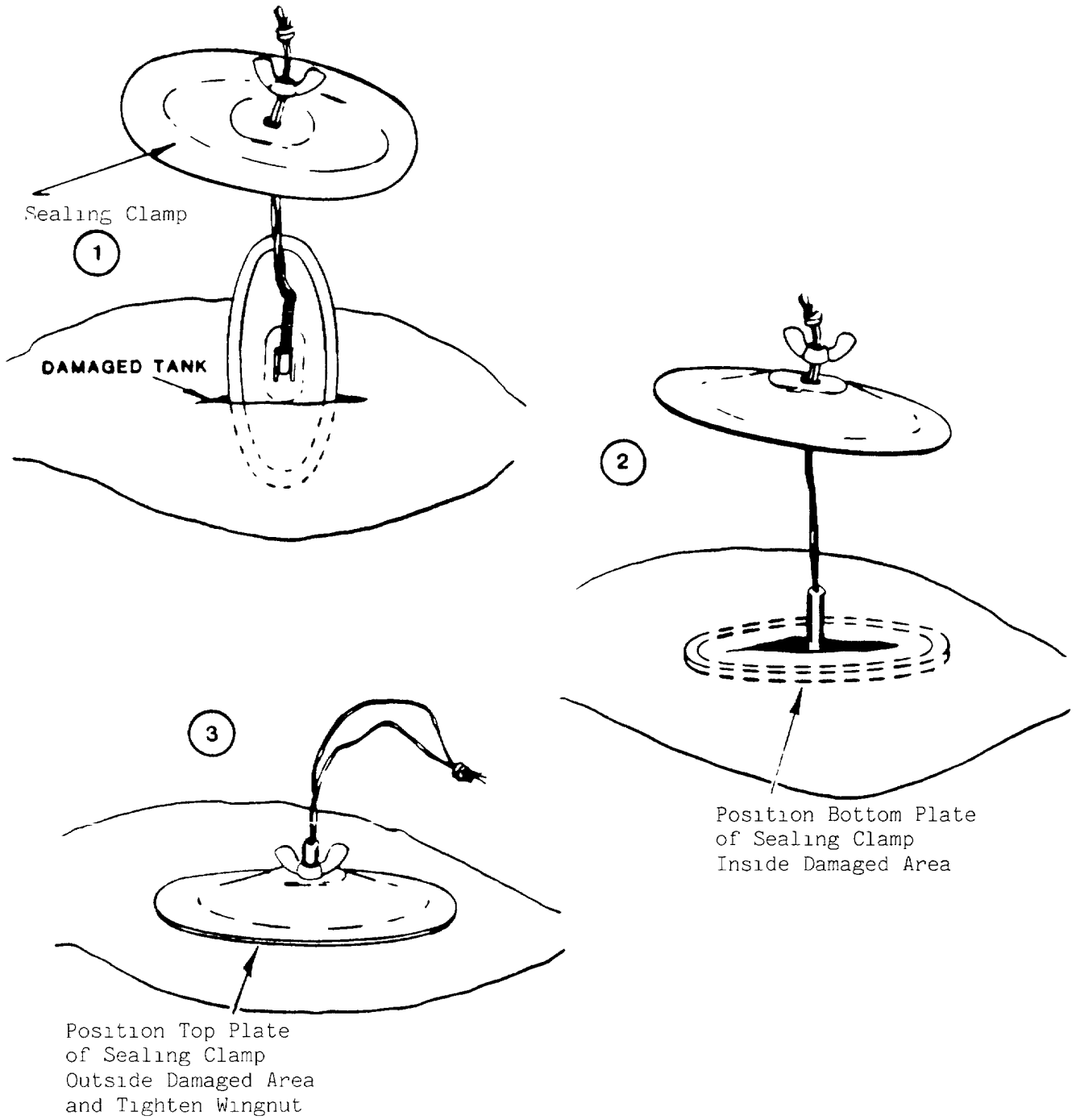

Figure V. Repairing Tank Envelope with Sealing Clamp

5.0 Maintenance Instructions (continued)

5.4 Corrective Maintenance (continued)

5.4.3 Vent Assembly. See Figure VI.

a. Disassembly

- (1) Disconnect female coupling from flange adapter by pulling outward on cam arms.
Lift female coupling from adapter. Remove gasket from female coupling.
- (2) Remove vent standpipe from coupling by turning counterclockwise.
- (3) Separate relief valve from vent stand-pipe by turning valve counterclockwise.
- (4) Using wrench, remove bolts and washers. Lift flanged adapter from tank fitting.
- (5) Remove "O" Ring from groove in tank fitting.

b. Repair and Replacement

- (1) Clean all parts by wiping with a cloth.
- (2) Inspect all parts for cracks, dents, breaks or wear. If any parts are no longer serviceable, replace before assembly.
- (3) Check that vent hole in relief valve is clear.

5.4.3 Vent Assembly (continued)

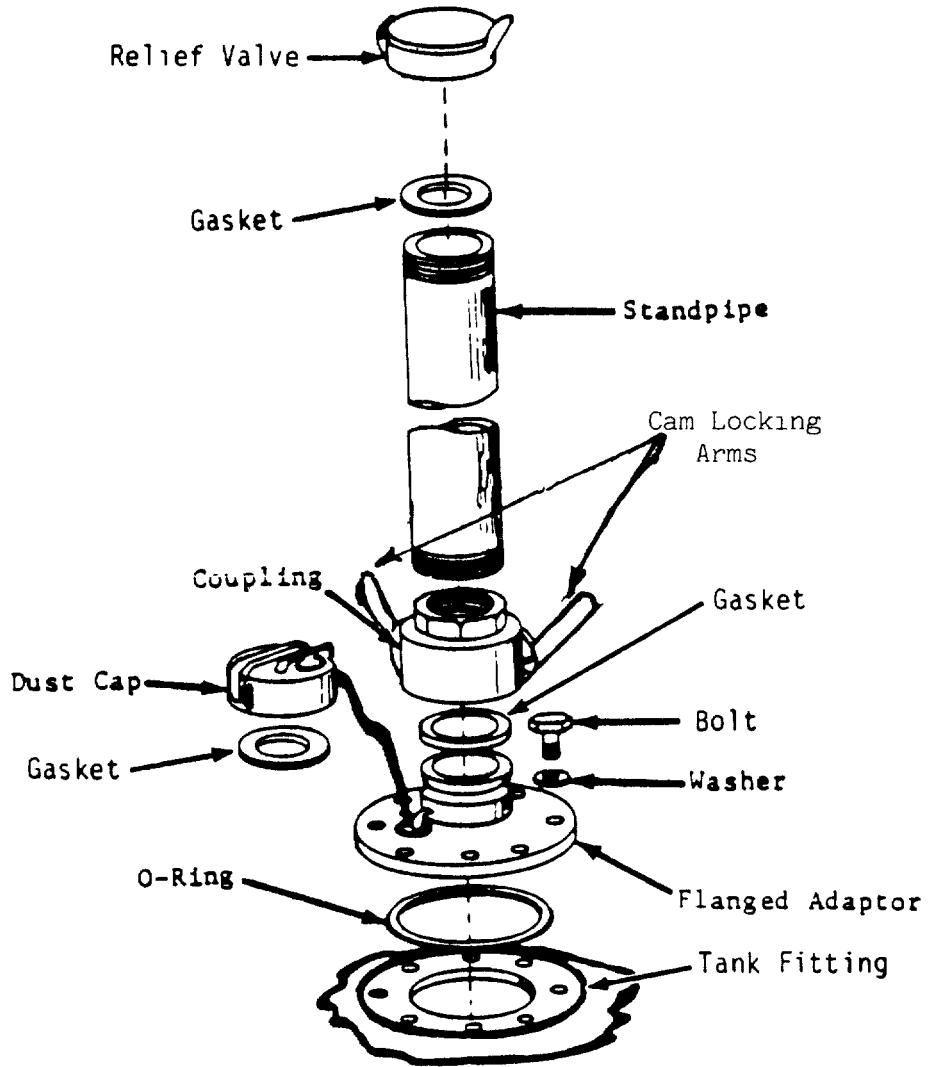

Figure VI. Vent Assembly

5.0 Maintenance Instructions (continued)

5.4 Corrective Maintenance (continued)

5.4.3 Vent Assembly (continued)

c. Reassembly

- (1) Place "O" Ring into groove in tank fitting.
- (2) Place flanged adapter on tank fitting. Rotate until holes in flange are in line with tapped holes in fitting. Place washers over bolts. Place bolts through holes in flange. Using wrench tighten bolts.
- (3) Place relief valve on vent standpipe until standpipe contacts "O" Ring gasket. Turn relief valve clockwise until tight.
- (4) Insert vent standpipe into coupling and turn standpipe clockwise until tight.
- (5) Insert coupling gasket into female coupling. Check that cam level arms of coupling are in an outward position. Place female coupling onto flanged adapter. Pull cam arms inward until they lock.

5.0 Maintenance Instructions (continued)

5.4 Corrective Maintenance (continued)

5.4.4 Filler/Discharge Assembly. See Figure VII.

a. Disassembly

- (1) Pull outward on cam arms. Remove elbow from flanged adapter.
- (2) Remove elbow gasket from inside of elbow.
- (3) Using wrench, remove hexagon head bolts and washers. Remove closure plate from tank fitting.
- (4) Remove "O" Ring from groove in tank fitting.
- (5) Using wrench, remove hexagon head bolts and washers from remaining assembly. Remove flanged adapter and gasket from top of closure plate. Remove suction stub from gasket from bottom of closure plate.

b. Repair and Replacement

- (1) Clean all parts by wiping with a cloth.
- (2) Inspect all parts for cracks, dents or wear. If any parts are no longer serviceable, replace before reassembly.

5.4.4 Filler/Discharge Assembly (continued)

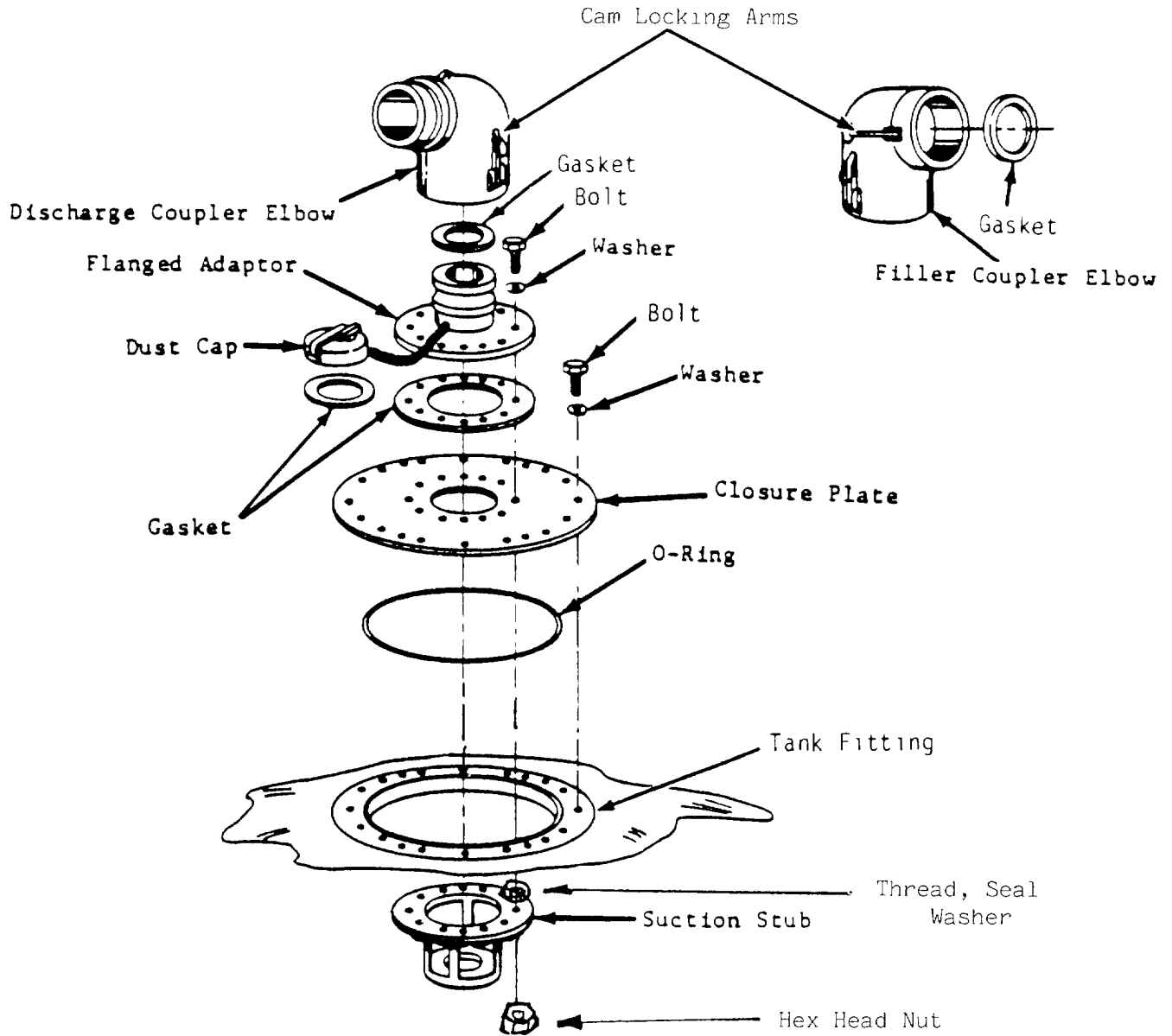

Figure VII. Filler/Discharge Assemblies

5.0 Maintenance Instructions (continued)

5.4 Corrective Maintenance (continued)

5.4.4 Filler/Discharge Assembly (continued)

c. Reassembly

- (1) Place suction stub on flat surface. Ensure ring with nut holes is facing up.
- (2) Place gasket and closure plate onto suction stub.
- (3) Place flanged adapter gasket on closure plate.
- (4) Place flanged adapter on gasket.
- (5) Place washers on bolts. Insert bolts through holes of flanged adapter and mate with holes in closure plate. Using a wrench, tighten bolts.
- (6) Place "O" Ring into groove in tank fitting.
- (7) Place closure plate onto tank plate assembly.
- (8) Place washers over bolts. Insert bolts through closure plate and into tapped holes in tank fitting. Using wrench, tighten bolts.
- (9) Place elbow gasket into elbow.
- (10) Place elbow onto flanged adapter. Push cam arms inward until they lock.

5.0 Maintenance Instructions (continued)

5.4 Corrective Maintenance (continued)

5.4.5 Drain Assembly. See Figure VIII.

a. Disassembly

- (1) Using wrench, remove bolts and washers attaching drain assembly to tank fitting.
- (2) Remove drain fitting and attached hardware.
- (3) Remove "O" Ring from groove in tank fitting.
- (4) Turn valve counterclockwise to disconnect it from drain hose. Remove valve.
- (5) Turn drain hose counterclockwise to disconnect it from drain fitting. Remove hose.

b. Repair and Replacement

- (1) Clean all parts by wiping with a cloth.
- (2) Inspect all parts for cracks, dents, breaks or wear. If any parts are no longer serviceable, replace before reassembly.

5.4.5 Drain Assembly (continued)

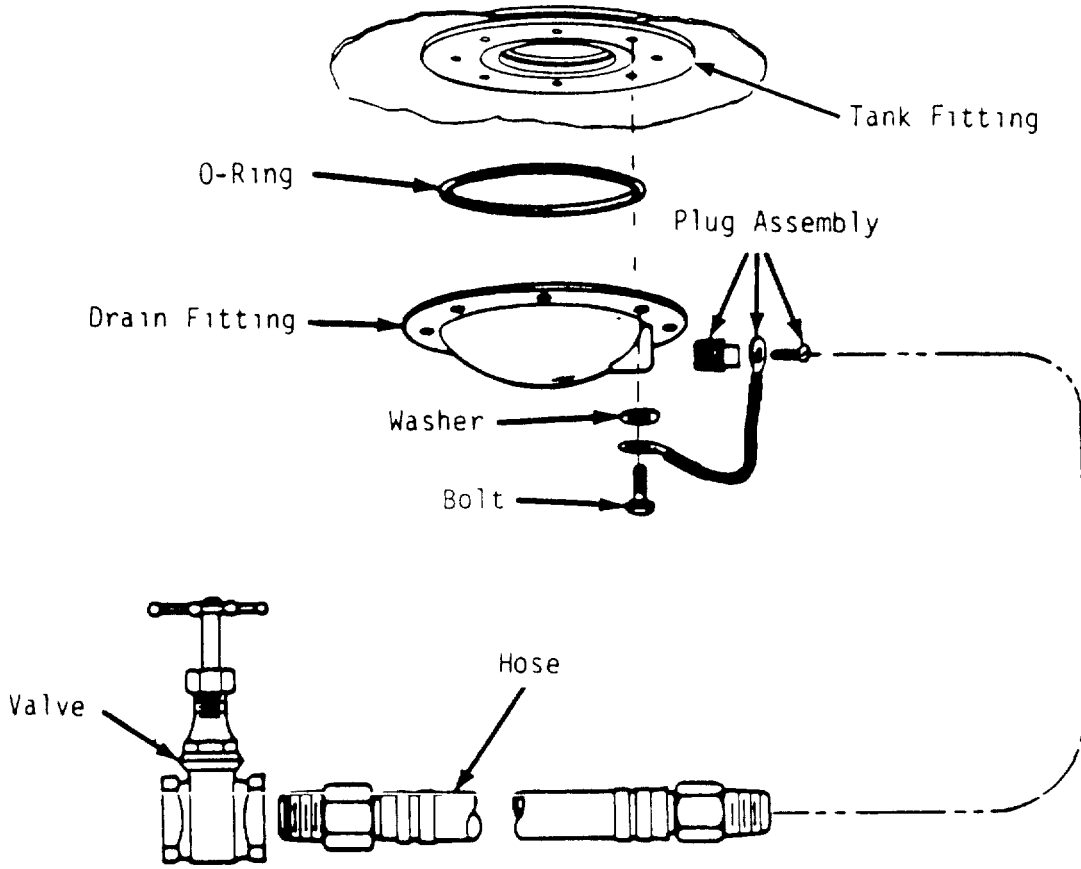

Figure VIII. Drain and Hose Assembly

5.0 Maintenance Instructions (continued)

5.4 Corrective Maintenance (continued)

5.4.5 Drain Assembly (continued)

c. Reassembly

- (1) Place drain hose on drain fitting. Turn hose clockwise until tight.
- (2) Place valve on drain hose. Turn valve clockwise until tight.
- (3) Place "O" Ring into groove on tank fitting.
- (4) Place drain fitting on tank fitting. Make sure hose and valve will extend from underneath tank.
- (5) Place washers over bolts. Insert bolts through drain fitting and into tank fitting.
Using wrench, tighten bolts.

5.4.6 Filler/Discharge Valve Assembly. See Figure IX.

a. Disassembly

- (1) Pull cam arms on hose assembly female coupling outward. Remove hose assembly from valve assembly.
- (2) Using wrench, remove hexagon nuts and lockwashers from hexagon head bolts on male coupling on valve assembly. Remove bolts and flatwashers. Remove male coupling and gasket from valve assembly.

5.4.6 Filler/Discharge Valve Assembly (continued)

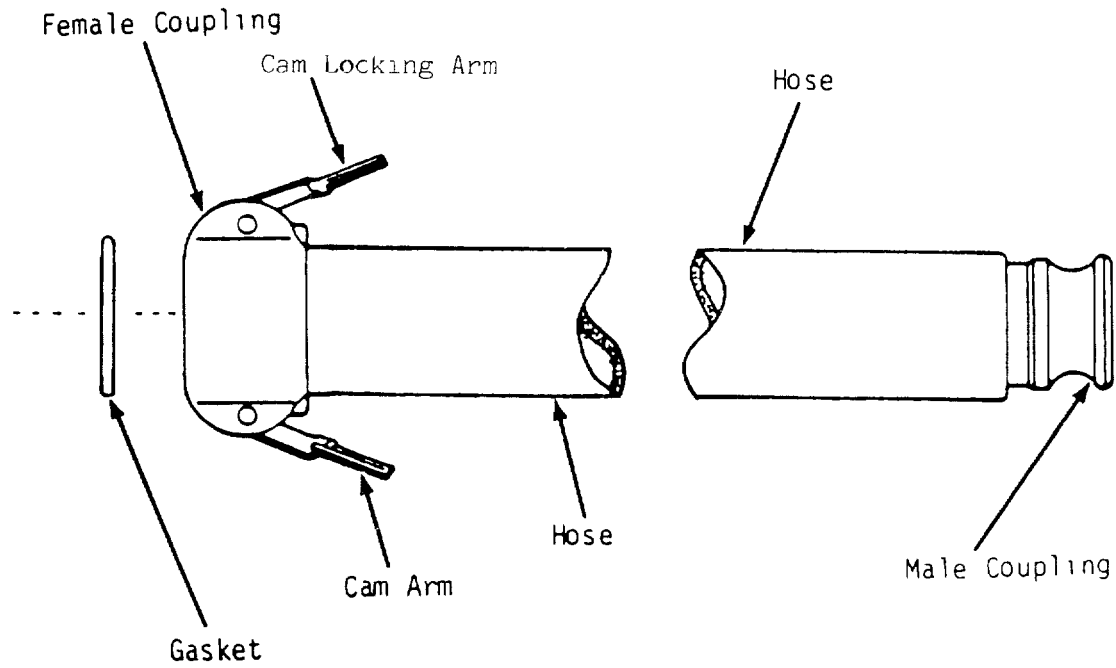
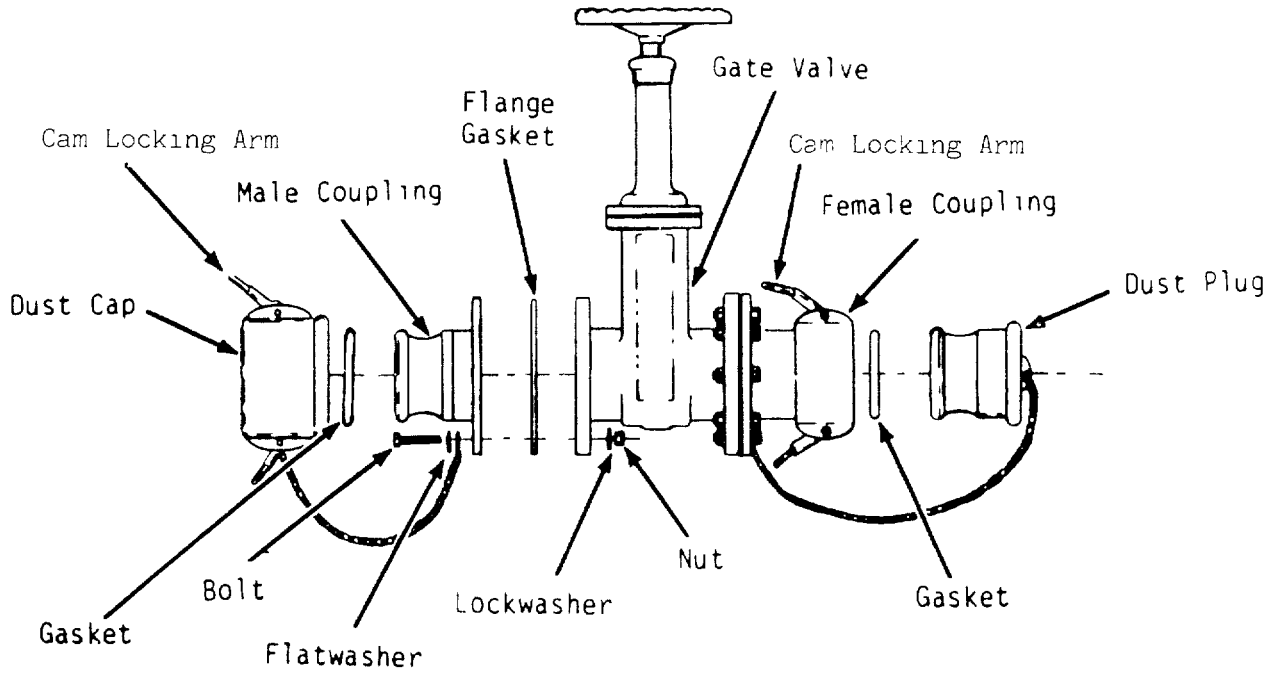

Figure IX. Filler/Discharge Valve and Hose Assembly

5.0 Maintenance Instructions (continued)

5.4 Corrective Maintenance (continued)

5.4.6 Filler/Discharge Valve Assembly (continued)

a. Disassembly (continued)

- (3) Using a wrench, remove hexagon nuts and lockwashers from hexagon head bolts securing female coupling to valve assembly. Remove bolts and flatwashers. Remove female coupling and gasket.
- (4) Remove gaskets from hose assembly female coupling and valve assembly female coupling.

b. Repair and Replacement

- (1) Clean all parts by wiping with a cloth.
- (2) Inspect all parts for cracks, dents, breaks or wear. If any parts are no longer serviceable, replace before re-assembly.

c. Reassembly

- (1) Place gasket in valve assembly female coupling and in hose assembly female coupling.
- (2) Place 4" flange gasket and female coupling on valve assembly.
- (3) Assemble with flatwashers on bolts. Insert bolts through coupling, gasket, and valve assembly.

5.0 Maintenance Instructions (continued)

5.4 Corrective Maintenance (continued)

5.4.6 Filler/Discharge Valve Assembly (continued)

- (4) Place lockwashers and nuts on bolts. Using a wrench, tighten nuts.
- (5) Place 41" flange gasket and male coupling on valve assembly.
- (6) Assemble with flatwashers on bolts. Insert bolts through coupling, gasket and valve assembly.
- (7) Place lockwashers and nuts on bolts. Using wrench, tighten nuts.
- (8) Check hose assembly female coupling. Ensure coupling is clean and serviceable gasket is in place.
- (9) Insert male coupling on valve assembly into female hose assembly coupling. Push cam arms on female coupling inward until they lock.

5.4.7 Hose Assembly

a. Disassembly of 4"1 Hose

- (1) Drain tank.
- (2) Disconnect hose from Filler/Discharge Assembly by pulling coupling cam arms outward.
- (3) Disconnect hose from valve assembly by pulling coupling cam arms outward.

5.0 Maintenance Instructions (continued)

5.4 Corrective Maintenance (continued)

5.4.7 Hose Assembly (continued)

b. Disassembly of Drain Hose

- (1) Refer to Paragraph 5.4.5 a. steps (4) and (5).

c. Replacement

- (1) Unpack new hoses and check couplings for serviceable gaskets.

d. Reassembly of 4" Hose

- (1) Clean filler/discharge assembly coupling.
- (2) Connect mating hose connections. Push both cam arms closed at the same time.
- (3) Connect valve assembly to other end of hose. Push both cam arms closed at the same time.

e. Reassembly of Drain Hose

- (1) Refer to Paragraph 5.4.5 c. steps (1) and (2).

5.4.8 Performance Verification

The only performance verification for the 50, 000 gallon collapsible water tank is a visual inspection of the part or parts that have been repaired. If the procedures in this manual do not repair the equipment, notify your supervisor.

6.0 Preparation for Reshipment and Storage

6.1 Removing Tank from Service

Prior to reshipment and storage, the 50, 000 gallon collapsible water tank will be emptied and refolded.

- a. Empty tank. Refer to draining procedure in Paragraph 4.4 of this manual.
- b. Disconnect all hoses, elbows and vent assembly from tank by pulling outward on cam arms and separating couplings.
- c. Install all dust caps and dust plugs on couplings and fittings.
- d. Remove drain hose and valve.
- e. Fold the up-slope end of tank to opposite side.

Refer to Paragraph 4.7.

- f. Roll up slope end of folded tank toward the drain assembly.

6.2 Storage

a. Storage Data

Temperature range: 25° F to 125°F (31.7°C to 51.7°C). Refer to Note and Caution in Paragraph 4.5 of this manual.

b. Storage

- (1) Keep tank and accessories in crate when tank is not in use.
- (2) If possible, store crated tank in cool, dark and dry area.

APPENDIX A

REFERENCES

A-1 SCOPE

This appendix lists all forms, field manuals, technical manuals and other publications referenced in this manual.

A-2 FORMS

Quality Deficiency Report SF 368

Recommended Changes to Equipment

Technical Publications DA Form 2028-2

Report of Discrepancy (ROD) SF 364

A-3 FIELD MANUALS

Planning and Conducting Chemical,

Biological, Radiological (CBR)

and Nuclear Defense Training FM 21-48

A-4 TECHNICAL MANUALS

Administrative Storage of Equipment TM 740-90-1

The Army Maintenance Management System (TAMMS)..... DA PAM 738-750

APPENDIX B

MAINTENANCE ALLOCATION CHART

SECTION I

INTRODUCTION

B-1 GENERAL

- a. This section provides a general explanation of all maintenance and repair functions authorized at various maintenance categories.
- b. The Maintenance Allocation Chart (MAC) in section II of this appendix designates overall authority and responsibility for the performance of maintenance functions to the end item or component. The application of the maintenance functions to the end item or component will be consistent with the capacities and capabilities of the designated maintenance categories.
- c. Section III of this appendix lists the tools and test equipment (both special tools and common tool sets) required for each maintenance function as referenced from Section II of this appendix.

B2 MAINTENANCE FUNCTIONS. Maintenance functions will be limited to and defined as follows:

- a. Inspect. To determine the serviceability of an item by comparing its physical, mechanical and/or electrical characteristics with established standards through examination (e.g., by sight, sound or feel).

B-2 **MAINTENANCE FUNCTIONS. (continued)**

- b. Test. To verify serviceability by measuring the mechanical, pneumatic, hydraulic or electrical characteristics of an item and comparing those characteristics with prescribed standards.
- c. Service. Operations required periodically to keep an item in proper operating condition; i.e., to clean (includes decontaminate, when required). to preserve, to drain, to paint or to replenish fuel, lubricants, chemical fluids or gases.
- d. Adjust. To maintain or regulate, within prescribed limits, by bringing into proper or exact position, or by setting the operating characteristics to specified parameters.
- e. Aline. To maintain or regulate, within prescribed limits, by bringing into proper or exact position, or by setting the operating characteristics to specified parameters.
- f. Calibrate. To determine and cause corrections to be made or to be adjusted on instruments or test, measuring and diagnostic equipment used in precision measurement. Consists of comparisons of two instruments, one of which is a certified standard of known accuracy, to detect and adjust any discrepancy in the accuracy of the instrument being compared.
- g. Remove/Install. To remove and install the same item when required to perform service or other maintenance functions. Install may be the act of emplacing, seating, or fixing into position a spare, repair part or module (component or assembly) in a manner to allow the proper functioning of an equipment or system.
- h. Replace. To remove an unserviceable item and install a serviceable counterpart in its place "Replace" is authorized by the MAC and is shown as the 3d position code of the SMR code.

B-2 MAINTENANCE FUNCTIONS. (continued)

1. Repair. The application of maintenance services ¹, including fault location/troubleshooting ², removal/installation, and disassembly/assembly ³ procedures, and maintenance actions ⁴ to identify troubles and restore serviceability to an item by correcting specific damage, fault, malfunction, or failure in a part, subassembly, module (component or assembly), end item or system.
- j. Overhaul. That maintenance effort (service/action) prescribed to restore an item to a completely serviceable/operational condition as required by maintenance standards in appropriate technical publications (i.e., DMWR). Overhaul is normally the highest degree of main tenance performed by the Army. Overhaul does not normally return an item to like new condition.
- k. Rebuild. Consists of those services/actions necessary for the restoration of unserviceable equipment to a like new condition in accordance with original manufacturing standards. Rebuild is the highest degree of material maintenance applied to Army equipment. The re build operation includes the act of returning to zero those age measurements (hours/miles, etc.) considered in classifying Army equipment/components.

¹ Services - inspect, test, service, adjust, aline, calibrate, and/or replace.

² Fault locate/troubleshooting - The process of investigating and detecting the cause of equipment malfunctioning; the act of isolating a fault within a system or unit under test (UUT).

³ Disassemble/assemble encompasses the step by step taking apart (or break down) or a spare/functional group coded item to the level of its least componency identified as maintenance significant (i.e., assigned an SMR code) for the category of maintenance under consideration.

⁴ Actions welding, grinding, riveting, straightening, facing, re-machinery, and/or resurfacing.

B-3 EXPLANATION OF COLUMNS IN THE MAC, SECTION II

- a. Column 1. Group Number. Column 1 lists functional group code numbers, the purpose of which is to identify maintenance significant components, assemblies, subassemblies, and modules with the next higher assembly. End item group number shall be "00"
- b. Column 2. Component/Assembly. Column 2 contains the names of components assemblies, subassemblies, and modules for which maintenance is authorized.
- c. Column 3. Maintenance Function. Column 3 lists the functions to be performed on the item listed in Column 2. (For detailed explanation of these functions, see paragraph B-2.)
- d. Column 4. Maintenance Category. Column 4 specifies, by the listing of a work time figure in the appropriate subcolumn(s), the category of maintenance authorized to perform the function listed in Column 3. This figure represents the active time required to perform that main tenance function at the indicated category of maintenance. If the number or complexity of the tasks within the listed maintenance function vary at different maintenance categories, appropriate work time figures will be shown for each category. The work time figure represents the average time required to restore an item (assembly, subassembly, component, module, end item, or system) to a serviceable condition under typical field operating conditions. This time includes preparation time (including any necessary disassembly/assembly time), troubleshooting/fault location time, and quality assurance/quality control time in addition to the time required to perform the specific tasks identified for the maintenance functions authorized in the

B-3 EXPLANATION OF COLUMNS IN THE MAC, SECTION II (continued)

d. (continued)

maintenance allocation chart. The system designations for the various maintenance categories are as follows:

- C Operator or crew
- O..... Organizational Maintenance
- F Direct Support Maintenance
- H..... General Support Maintenance
- L Specialized Repair Activity (SRA)⁵
- D..... Depot Maintenance

- e. Column 5. Tools and Equipment. Column 5 specifies, by code, those common tool sets (not individual tools) and special tools, TMDE, and support equipment required to perform the designated function.
- f. Column 6. Remarks. This column shall, when applicable, contain a letter code, in alphabetic order, which shall be keyed to the remarks contained in Section IV.

⁵ This maintenance category is not included in Section II, column (4) of the Maintenance Allocation Chart. To identify functions to this category of maintenance, enter a work time figure in the "H" column of Section II, column (4), and use an associated reference code in the Remarks column (6). Key the code to Section IV, Remarks, and explain the SRA complete repair application there. The explanatory remark(s) shall reference the specific Repair Parts and Special Tools List (RPSTL) TM which contains additional SRA criteria and the authorized spare/repair parts.

B-4 **EXPLANATION OF COLUMNS IN TOOL AND TEST EQUIPMENT REQUIREMENTS,**
SECTION III

- a. Column 1. Reference Code. The tool and test equipment reference code correlates with a code used in the MAC, Section II, Column 5.
- b. Column 2. Maintenance Category. The lowest category of maintenance authorized to use the tool or test equipment.
- c. Column 3. Nomenclature. Name or identification of the tool or test equipment.
- d. Column 4. National Stock Number. The National stock number of the tool or test equipment.
- e. Column 5. Tool Number. The manufacturer's part number.

Section II. Maintenance Allocation Chart

for

Tank, Fabric, Collapsible, 50, 000 Gallon Water

(1) GROUP NUMBER	(2) COMPONENT ASSEMBLY	(3) MAINTENANCE FUNCTION	(4) MAINTENANCE CATEGORY					(5) TOOLS AND EQUIPMENT	(6) REMARKS
			C	O	F	H	D		
00	Tank, Fabric, Col- lapsible 50, 000 Gallon Water	Inspect	.2						
		Replace		1.0					
		Repair	.5						
01	Tank Envelope	Inspect	.2				1	. . .	
		Replace		1.0					
		Repair	.5						
02	Vent Assembly	Inspect	.2				1	. . .	
		Replace		.2					
		Repair			.5				
03	Filler Assembly	Inspect	.2				1	. . .	
		Replace		.2					
		Repair		.5					
04	Discharge Assembly	Inspect	.2	.2			1	. . .	
		Replace		.2					
		Repair		.5					
05	Drain Assembly	Inspect	.2				1	. . .	
		Replace		.2					
		Repair		.5			1	. . .	
06	Valve Assembly	Inspect	.2				1	. . .	
		Replace		.2					
		Repair		.5					
07	Hoses	Inspect	.2				1	. . .	
		Replace		.2					
		46							

Section III Tool and Test Equipment Requirements

for

Tank, Fabric, Collapsible, 50, 000 Gallon Water

TOOL OR TEST EQUIPMENT REF CODE	MAINTENANCE CATEGORY	NOMENCLATURE	NATIONAL/NATO STOCK NUMBER	TOOL NUMBER
1		Tool Kit, General Mechanics	5180-00-177-7033	█

47 Change 1

APPENDIX C

REPAIR PARTS AND SPECIAL TOOLS LIST

SECTION I

INTRODUCTION

- C1** **SCOPE.** This manual lists and authorizes spares and repair parts; special tools; special test, measurement and diagnostic equipment (TMDE); and other special support equipment required for performance of organizational, direct support, and general support maintenance of the 50, 000 gallon collapsible water tank.
- C-2** **GENERAL.** This Repair Parts and Special Tools List is divided into the following sections:
- a. Section II. Repair Parts List. A list of spares and repair parts authorized by this RPSTL for use in the performance of maintenance. The list also includes parts which must be removed for replacement of the authorized parts. Part lists are composed Of functional groups in ascending alphanumeric sequence, with the parts in each group listed in ascending figure and item number sequence. Bulk materials are listed in NSN sequence.
 - b. Section III. Special Tools List. Not applicable.
 - c. Section IV. National Stock Number, and Part Number Index. A list, in National item identification number (NIIN) sequence, of all National stock numbers (NSN) appearing in the listings, followed by a list in alphanumeric sequence of all part numbers appearing in the listings. National stock numbers and part number's are cross referenced to each illustration figure and item number appearance.

C-3 **EXPLANATION OF COLUMNS.**

- a. Illustration (Column (1)). This column is divided as follows:
 - (1) ((a)FIG. NO.) Figure Number. Indicates the figure number illustrating an exploded view of a functional group.
 - (2) ((b) ITEM NO.). Indicates the number used to identify items called out in the illustration.
- b. SMR CODE (Column 2)). Not applicable.
- c. National Stock Number (Column (3)). Lists the National Stock Number (NSN) assigned to the item. Use the NSN for requests/requisitions.
- d. FSCM (Column (4)). The Federal Supply Code for Manufacturer (FSCM) is a 5-digit numeric code which is used to identify the manufacturer, distributor, or Government agency, etc., that supplies the item.
- e. Part Number (Column (5)). Indicates the primary number used by the manufacturer (individual, company, firm, corporation or Government activity), which controls the design and characteristics of the item by means of its engineering drawings, specifications standards, and inspection requirements to identify an item or range of items.

NOTE: When you use a NSN to requisition an item, the item you receive may have a different part number from the part ordered, but go ahead and use or furnish it as the replacement part.
- f. Description (Column (6)). This column includes the following information:
 - (1) The Federal item name, and when required, a minimum description to identify the item.

C-3 EXPLANATION OF COLUMNS (continued)

- f. Description (Column 6). (continued) -
- (2) Items that are included in kits and sets are listed below the name of the kit or set.
 - (3) Spare/repair parts that make up an assembled item are listed immediately following the assembled item line entry.
 - (4) NSN's for bulk materials are referenced in the description column in the line item entry for the item to be manufactured/ fabricated.
 - (5) When the part to be used differs between serial numbers of the same model, the effective serial numbers are shown as the last line of the description.
- g. U/M (Column 7). The Unit of Measure (U/M) indicates the measure (e.g., foot, gallon, pound) or count (e.g., each, dozen, gross) of a listed item. A two character alpha code (e.g., FT, GL, LB, EA, DZ, GR) appears in this column differs from the Unit of Issue(U/I) code listed in the Army Master Data File (AMDA), request the lowest U/I that will satisfy your needs.
- h. OTY INC IN UNIT (Column 8). The Quantity Incorporated in Unit (OTY INC IN UNIT) indicates the quantity of the item used in the breakout shown on the illustration figure, which is prepared for a functional group, subfunctional group, or an assembly. A "V" appearing in this column in lieu of a quantity indicates that no specific quantity is applicable (e.g., shims, spacers).

C-4 SPECIAL INFORMATION. Not applicable.

C-5 HOW TO LOCATE REPAIR PARTS.

- a. When National Stock Number or Part Number is Not Known:

C-5 HOW TO LOCATE REPAIR PARTS. (continued)

a. When National Stock Number or Part Number is Not Known:

- (1) First. Using the table of contents, determine the functional group or subfunctional group to which the item belongs. This is necessary since figures are prepared for function groups and subfunctional group, and listings are divided into the same groups.
- (2) Second. Find the figure covering the functional group or sub functional group to which the item belongs.
- (3) Third. Identify the item on the figure and note the item number of the item.
- (4) Fourth. Refer to the Repair Parts List for the figure to find the line item entry for the item number noted on the figure.

b. When National Stock Number or Part Number is Known:

- (1) First. Using the index of National Stock Numbers and Part Numbers, find the pertinent National Stock Number or part number. The NSN index is in National Item Identification Number (NIIN)* sequence. The part numbers in the Part Number Index are listed in ascending alphanumeric sequence. Both indexes cross-reference you to the illustration figure and item number of the item you are looking for.

*The NIIN consists of the last 9 digits of the NSN (i.e., 5430-01-106-9677)
NSN
NIIN

- (2) Second. After finding the figure and item number, verify that the item is the one you are looking for, then locate the item number in the repair parts list for the figure.

C-6 ABBREVIATIONS. Not applicable.

Section II. REPAIR PARTS LIST

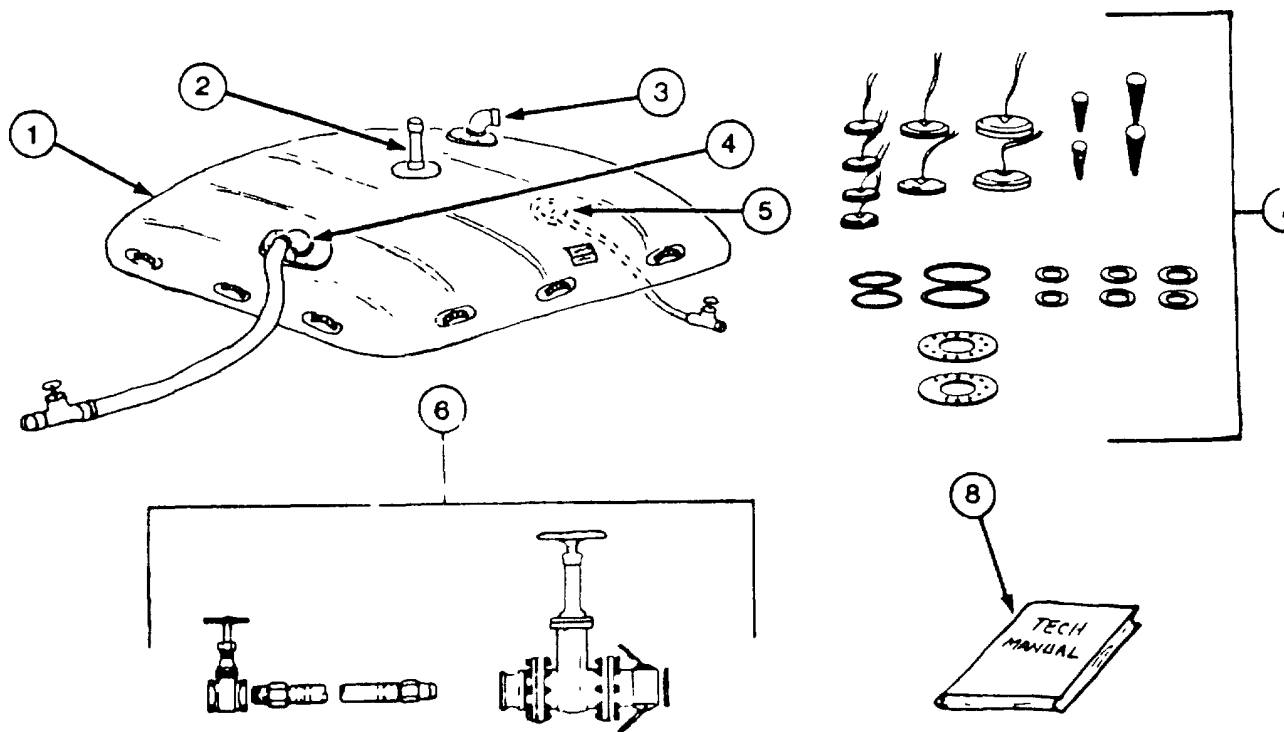

Figure C-1. Tank, Fabric, Collapsible, 50, 000 Gallon Water

LIST OF FUNCTIONAL GROUPS

(1) ILLUSTRATION		(2)	(3)	(4)	(5)	(6)	(7)	(8)
(a) FIG NO.	(b) ITEM NO.	SMR CODE	NATIONAL STOCK NUMBER	FSCM	PART NUMBER	DESCRIPTION USABLE ON CODE	U/M	QTY INC IN UNIT
C-1	-					Group 00 Tank, Fabric Collapsible, 50, CDO Gallon Water		
C-1	1				TBD	Tank Envelope	Ea	1
C-1	2				TBD	Vent Assembly	Ea	1
C-1	3				TBD	Filler Assembly	Ea	1
C-1	4				TBD	Discharge Assembly	Ea	1
C-1	5				TBD	Drain Assembly	Ea	1
C-1	6				TBD	Valve Assembly, 4"	St	1
C-1	7				TBD	Emergency Repair Items	St	1
C-1	8				TBD	Technical Manual	Ea	1

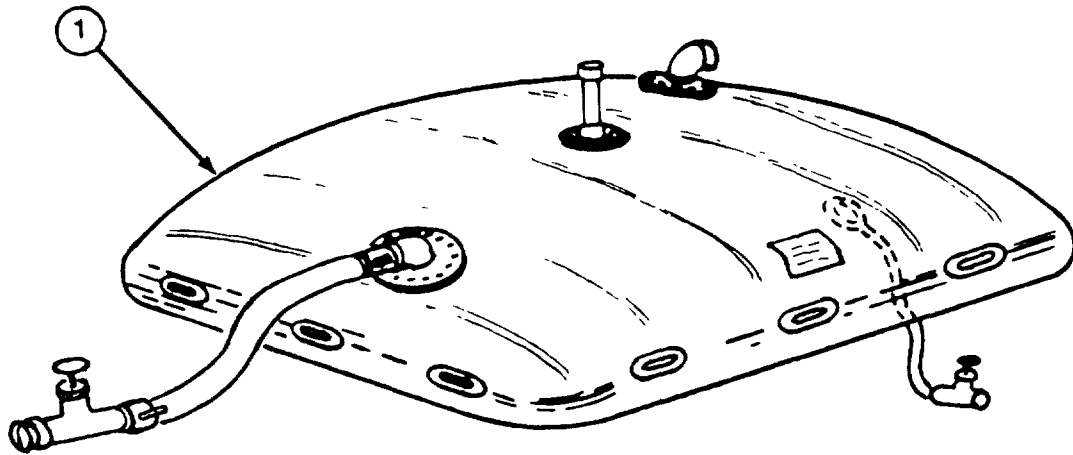

Figure C-2. Tank Envelope

LIST OF FUNCTIONAL GROUPS

(1) ILLUSTRATION		(2)	(3)	(4)	(5)	(6)	(7)	(8)
(a) FIG NO.	(b) ITEM NO.	SMR CODE	NATIONAL STOCK NUMBER	FSCM	PART NUMBER	DESCRIPTION USABLE ON CODE	U/M	QTY INC IN UNIT
C-2	1		5430-01-106-9677	05476	91005	Group 01 Tank Tank Envelope		

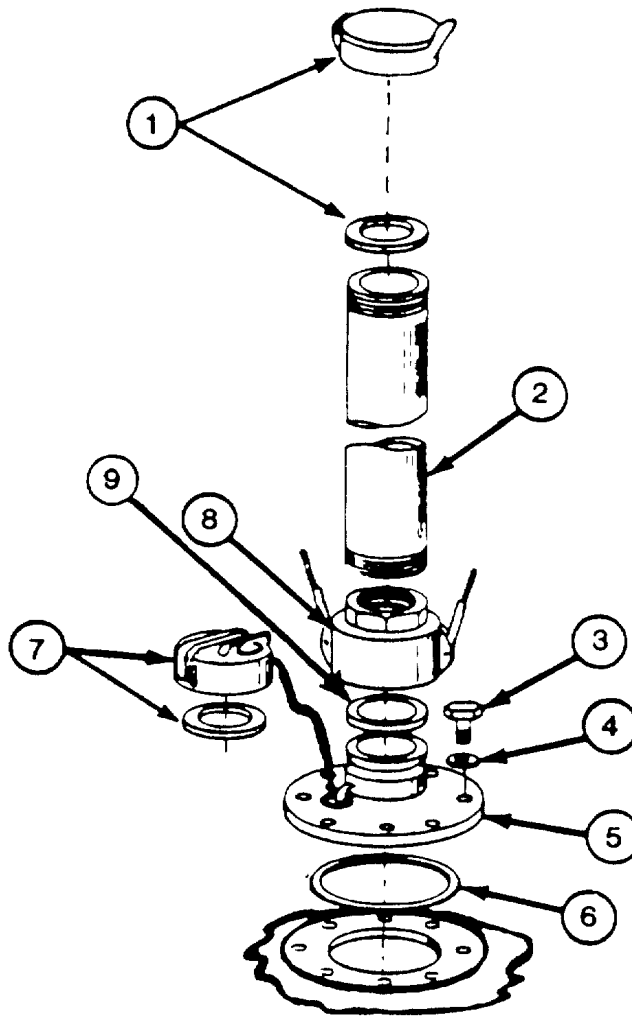

Figure C-3. Vent Assembly

LIST OF FUNCTIONAL GROUPS

(1) ILLUSTRATION		(2)	(3)	(4)	(5)	(6)	(7)	(8)
(a) FIG NO.	(b) ITEM NO.	SMR CODE	NATIONAL STOCK NUMBER	FSCM	PART NUMBER	DESCRIPTION USABLE ON CODE	U/M	QTY INC IN UNIT
C-3	1			05476	1,0374	Group 02 Vent Assembly		
C-3	2			05476	1,0443	Cap relief with Gasket	Ea	1
C-3	3		5305-00-225-3839	05476	1,0403	*Standpipe, 2" Nom, Schedule	Ea	1
C-3	4		5310-00-809-4058	05476	MS27183-10	Bolt, Hex-lid, 1/4-in. X 1.25"L	Ea	8
C-3	5			05476	MS27023-21	Washer, Flat, 1/4-in.	Ea	8
C-3	6		53-00-291-3085	05476	MS27028-11	Flange Adapter, Coupling	Ea	8
C3	7		4730-00-649-9100	05476	MS29513-250	"0" Ring	Ea	1
C-3	8		4720-00-649-9103	05476	MS27024-11	Dust Cap with chain and gasket	Ea	1
C-3	9		5310-00-612-2414	05476	MS27039-6	"Coupling, Q-D female, 2" Gasket, 2"	Ea	1
						*Assembled in one unit		

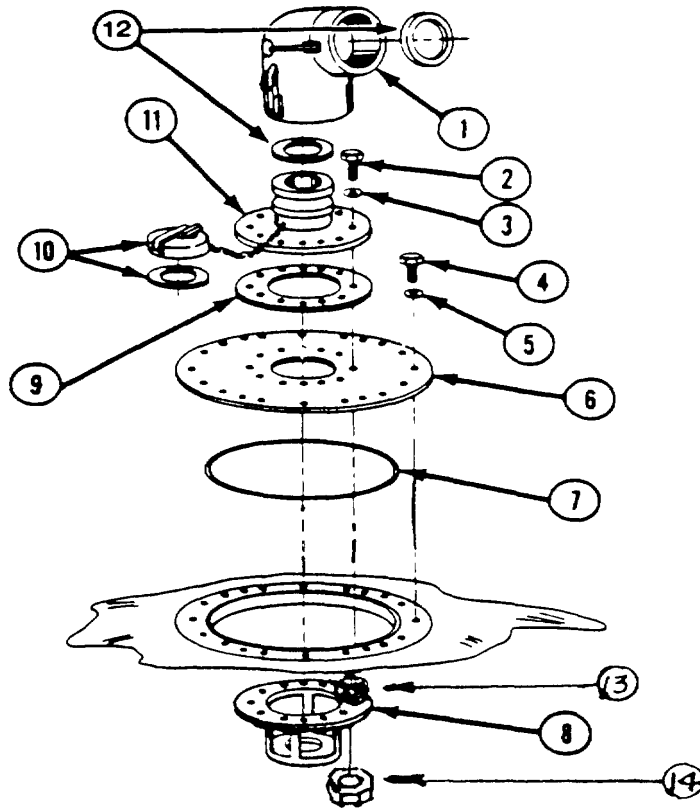

Figure C-4. Filler Assembly

LIST OF FUNCTIONAL GROUPS

(1) ILLUSTRATION		(2)	(3)	(4)	(5)	(6)	(7)	(8)
(a) FIG NO.	(b) ITEM NO.	SMR CODE	NATIONAL STOCK NUMBER	FSCM	PART NUMBER	DESCRIPTION	USABLE ON CODE	U/M
C-4	1			05476	M927019	Group 03 Filler Assembly		
C-4	2			05476	IS90725-64	Cplr, Elbow with gaskets.....	Ea	1
C-4	3			05476	MS27183-13	Bolt, Hex-Hd, 3/8-in x 1 SOOL.....	Ea	8
C-4	4		5305-00-225-3839	05476	MS90725-8	Washer, lock, 3/8-in.....	Ea	8
C-4	5		5310-00-809-4058	05476	MS27183-10	Bolt, Hex-Hd, 1/4-in. x 20 x 1 00"L.....	Ea	20
C-4	6			05476	90006	Washer, flat, 1/4-in.....	Ea	20
C-4	7		5330-00-524-0718	05476	MS90213-83	Closure Plate.....	Ea	1
C-4	8			05476	90005	'O' Ring.....	Ea	1
C-4	9		5330-00-647-2072	05476	1, 0352	Suction Stub.....	Ea	1
C-4	10			05476	M527028-17	Casket.....	Ea	2
C-4	11			05476	MS27023-17	Dust Cap with gasket and chain.....	Ea	1
C-4	12			05476	MS27030-9	Adaptor, Flanged.....	Ea	1
C-4	13			05476	1, 0362	Casket.....	Ea	2
C-4	14			05476	1, 0362	Washer, Thread, Seal.....	Ea	8
C-4 11			05476	M551967		Nut, Hex, 3/8-in.....	Ea	8

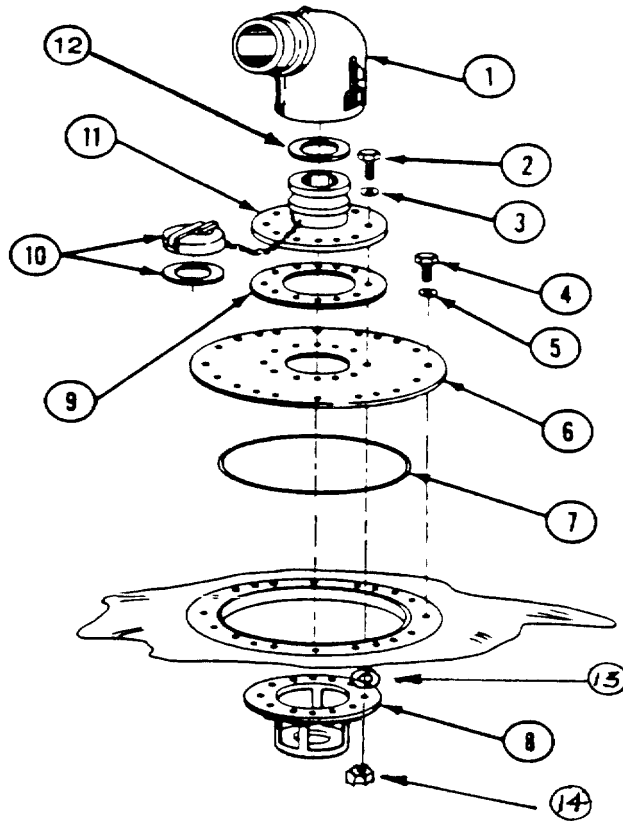

Figure C-5. Discharge Assembly

LIST OF FUNCTIONAL GROUPS

(1) ILLUSTRATION		(2)	(3)	(4)	(5)	(6)	(7)	(8)
(a) FIG NO.	(b) ITEM NO.	SMR CODE	NATIONAL STOCK NUMBER	FSCM	PART NUMBER	DESCRIPTION USABLE ON CODE	U/M	QTY INC IN UNIT
C-5	1			05476	1, 0356	Group 04 Discharge Assembly		
C-5	2				05476	Cplr, Elbow with Casket	Ea	1
C-5-3			05476	MS27183-13		MIS90725-64 Bolt, Hex-Hd, 3/8-in x 1 50"L	Ea	8
C-5	4		5105-00-225-3839	05476	MS90725-8	Washer, Lock, 3/8-in.....	Ea	8
C-5	5		5310-00-809-4058	05476	MS27183-10	Bolt, Hex-Hd, 1/4-in x 1.00"L.....	Ea	20
C-5	6			05476	90006	Washer, Flat, 1/4-in	Ea	20
C-5	7		5330-00-524-0718	05476	MS90213-83	Closure Plate.....	Ea	1
C-5	8			05476	90005	'O' Ring.....	Ea	1
C-5	9		5330-00-647-2072	05476	1,0352	Suction Stub.....	Ea	1
C-5	10			05476	MS27028-11	Gasket.....	Ea	1
C-5	11			05476	MS27033-17	Dust Cap with gasket and chain.....	Ea	1
C-5	12			05476	MS27030-9	Adaptor, Flanged.....	Ea	1
C-5	13			05476	1, 0362	Casket.....	Ea	1
C-5	14					Washer, Thread, Seal.....	Ea	8
						Nut, Hex, 3/8-in.....	Ea	8

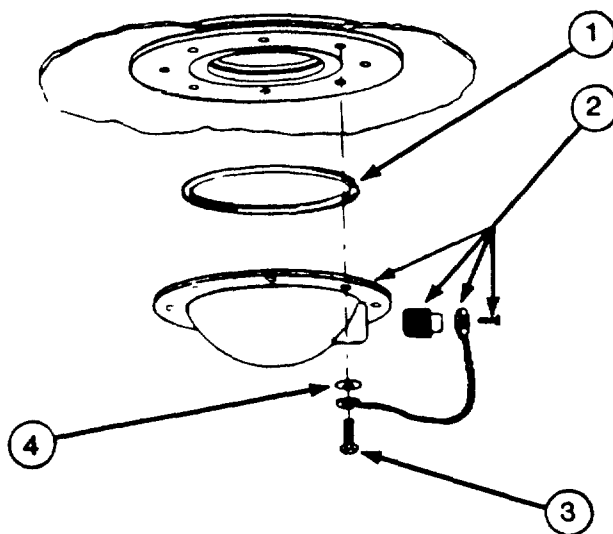

Figure C-6. Drain Assembly.

LIST OF FUNCTIONAL GROUPS

(1) ILLUSTRATION		(2)	(3)	(4)	(5)	(6)	(7)	(8)
(a) FIG NO.	(b) ITEM NO.	SMR CODE	NATIONAL STOCK NUMBER	FSCM	PART NUMBER	DESCRIPTION USABLE ON CODE	U/M	QTY INC IN UNIT
C-6	1		5330-00-291-3085	05476	MS29513-250	Group 5 Drain Assembly	Ea	1
C-6	2			05476	CFB-263-2	"O" Ring.....	Ea	1
C-6	3		5305-00-225-3839	05476	1, 0401	Plug, chain and screw.....	Ea	8
C-6	4		5310-00-809-4058	05476	MS27183-10	Bolt, Hex-Hd, 1/4-in 20 x 1 00".....	Ea	8
C-6	5			05476	90004-2	Washer, Flat, 1/4-in.	Ea	1
						Drain Fitting.....		

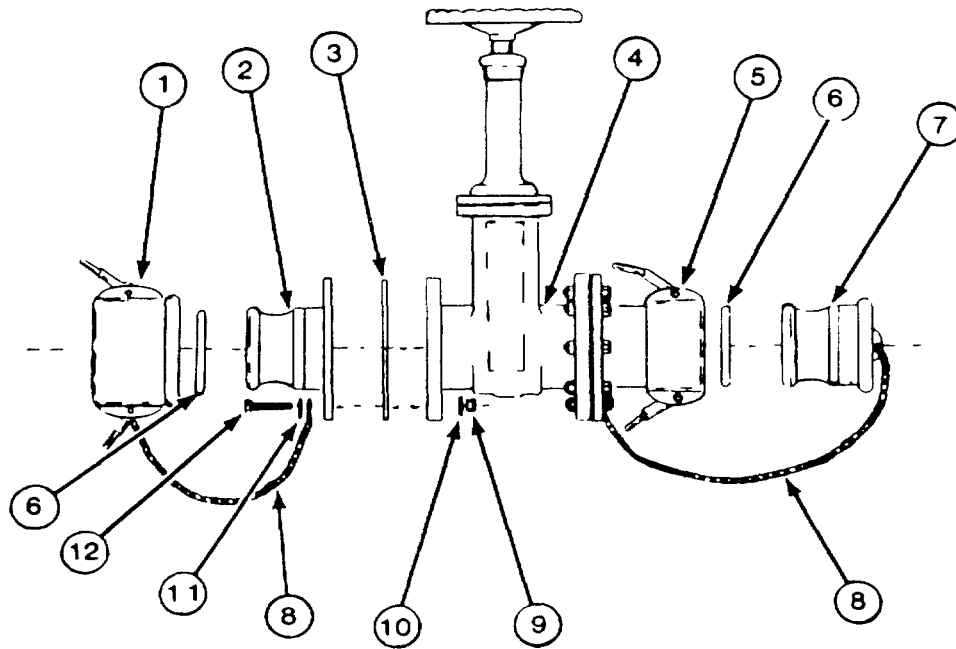

Figure C-7. Valve Assembly, 4"

LIST OF FUNCTIONAL GROUPS

(1) ILLUSTRATION		(2) SMR CODE	(3) NATIONAL STOCK NUMBER	(4) FSCM	(5) PART NUMBER	(6) DESCRIPTION USABLE ON CODE	(7) U/M	(8) QTY INC IN UNIT
(a) FIG NO.	(b) ITEM NO.							
C-7	1			05476	1, 0364	*Group 06 Valve Assembly, 4L"		
C-7	2			05476	MS27028-17	Dust Cap with gasket and cable.....	Ea	1
C-7 t	3		5330-00-647-2072	05476	M527023-17	Coupling Half, O-D Male, Flanged	Ea	1
C-7	4			05476	1, 0352	Gasket.....	Ea	1
C-7	5			31349	MIL-V-58039	Gate Valve, 4" Type 1	Ea	1
C-7	6			96906	MS27027-17	Coupling Half, O-D Female, Flanged	Ea	1
C-7	7			05476	MS27030-9	Gasket.....	Ea	2
C-7	8			05476	MS27029-17	*Dust Plug with Chain	Ea	1
C-7	9			05476	1,0364	'Chain, Coated Type II, Class 3.....	Ea	2
C-7	10		5310-00-637-9541	05476	MS51967	Nut, Hex.....	Ea	16
C-7	11			05476	MS27183-13	Washer, Lock 3/8-in.....	Ea	16
C-7	12			05476	1, 0572	Washer, Flat 3/8-in.	Ea	16
C-7				05476	MS90725-64	Bolt, Hex-Hd 3/8" x 1 50"	Ea	16
						*Complete Assembly		

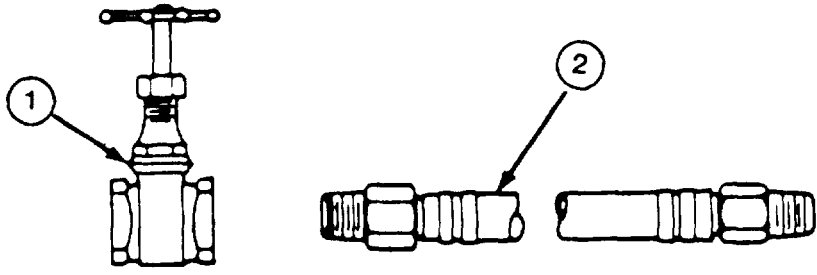

Figure C-8. Hoses

LIST OF FUNCTIONAL GROUPS

(1) ILLUSTRATION		(2)	(3)	(4)	(5)	(6)	(7)	(8)
(a) FIG NO.	(b) ITEM NO.	SMR CODE	NATIONAL STOCK NUMBER	FSCM	PART NUMBER	DESCRIPTION USABLE ON CODE	U/M	QTY INC IN UNIT
C-8	1		4820-00-287-6041	05476	1, 0365	Group 07 Hoses Valve, 1/2"	Ea	1
C-8	2			05476	1, 0375	Hose Assembly, 3/4" x 8 ft..... ZZ-H-601, Grade 3, Class II	Ea	1

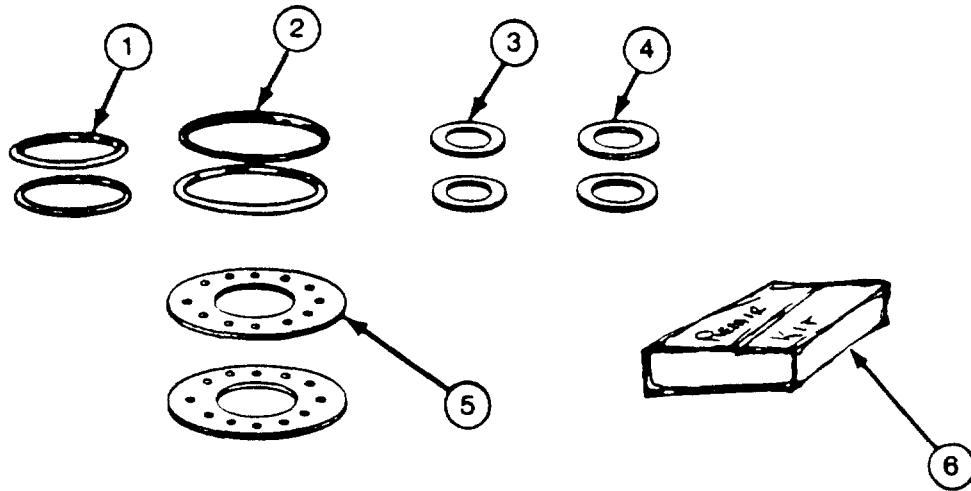

Figure C-9. Emergency Repair Items

LIST OF FUNCTIONAL GROUPS

(1) ILLUSTRATION		(2)	(3)	(4)	(5)	(6)	(7)	(8)
(a) FIG NO.	(b) ITEM NO.	SMR CODE	NATIONAL STOCK NUMBER	FSCM	PART NUMBER	DESCRIPTION USABLE ON CODE	U/M	QTY INC IN UNIT
C-9	1		5330-00-291-3085	05476	MS29513-250	Group 08 Emergency Repair Items	Ea	2
C-9	2		5330-00-524-0118	05476	M590213-83	"O" Ring	Ea	2
C-9	3			05476	MS27030-6	Gasket, Flange	Ea	2
C-9	4			05476	MS27030-9	Gasket, Flange	Ea	2
C-9	5		5330-00-647-2072	05476	1, 0352	Gasket, 4-inch Flange	Ea	2
C-9	6		5430-00-641-8957	05476	TBD	Emergency Repair Kit	Ea	1

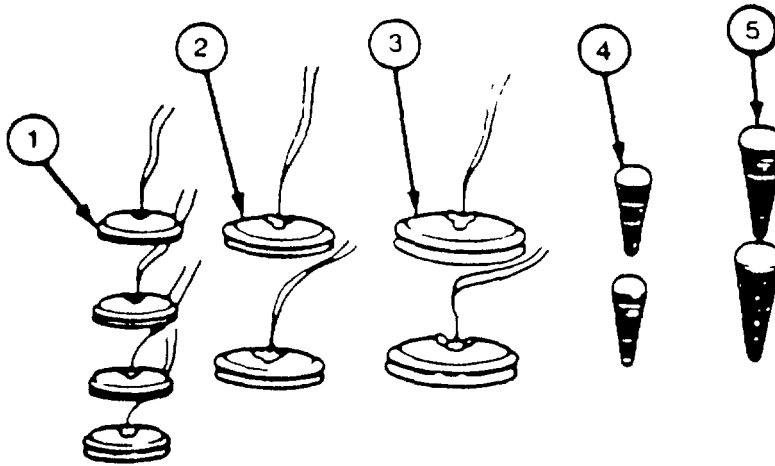

Figure C-10. Emergency Repair Kit Items

LIST OF FUNCTIONAL GROUPS

(1) ILLUSTRATION		(2)	(3)	(4)	(5)	(6)	(7)	(8)
(a) FIG NO.	(b) ITEM NO.	SMR CODE	NATIONAL STOCK NUMBER	FSCM	PART NUMBER	DESCRIPTION USABLE ON CODE	U/M	QTY INC IN UNIT
						Group 08 Emergency Repair Kit Items		
C-101		5430-00	591-6863	05476	1, 0139	Clamp, Sealing, 3-in.....	Ea	4
C-102		5430-00	591-6864	05476	1, 0140	Clamp, Sealing, 5-in.....	Ea	2
C-103		5430-00	591-6865	05476	1, 0141	Clamp, Sealing, 7-1/2-in.....	Ea	2
C-104		5510-00	255-9493	05476	1, 0430	Plug, Tapered, 3-in.....	Ea	2
C-105		5510-00	255-9692	05476	1, 0431	Plug, Tapered, 5-in.....	Ea	2

SECTION III. SPECIAL TOOLS LIST - NOT APPLICABLE

SECTION IV. NATIONAL STOCK NUMBER AND PART NUMBER INDEX

NATIONAL STOCK NUMBER INDEX

<u>Stock Number</u>	<u>Figure No.</u>	<u>Item Number</u>
5430-00-591-6863	C-10	1
5430-00-591-6864	C-10	2
5430-00-591-6865	C-10	3
5430-00-641-8957	C-9	6
5510-00-255-9493	C-10	4
5510-00-255-9692	C-10	5

PART NUMBER INDEX

<u>FSCM</u>	<u>PART NUMBER</u>	<u>STOCK NUMBER</u>	<u>FIG.</u>	<u>ITEM</u>
05476	1, 0374		C-3	1
81349	MIL-V-58039		C-7	4
	4 in., Type I			
05476	MS 27019 (1, 0357)		C-4	1
05476	MS 27023-17 (1, 0353)		C-4	11
			C-5	11
			C-7	2
05476	MS 27023-21 (1, 0354)		C-3	5
05476	MS 27024-11 (1, 0443)	4720-00-649-9103	C-3	8
96906	MS 27027-17		C-7	5
05476	MS 27028-11 (1, 0444)	4730-00-649-9100	C-3	7
05476	MS 27028-17 (1, 0358)		C-4	10
			C-5	10
			C-7	1

PART NUMBER INDEX (continued)

<u>FSCM</u>	<u>PART NUMBER</u>	<u>STOCK NUMBER</u>	<u>Figure No.</u>	<u>ITEM</u>
05476	MS 27029-17 (1, 0364)		C-7	7
05476	MS 27030-6 (1, 0350)	5310-00-612-2414	C-3	9
			C-9	3
05476	MS 27030-9 (1, 0351)		C-4	12
			C-5	12
			C-7	6
			C-9	4
05476	MS 27183-10 (1, 0410)	5310-00-809-4058	C-3	4
			C-4	5
			C-5	5
			C-6	4
05476	MS 27183-13 (1, 0411)	5310-00-087-7493	C-4	3
			C-5	3
			C-7	10
05476	MS 29513-250 (1, 0144)	5330-00-291-3085	C-3	6
			C-6	1
			C-9	1
05476	MS 51967(1, 0420)		C-7	9
			C-5	14
			C-4	14
05476	1, 0572		C-7	11
05476	MS 90213-83 (CFB-159)	5330-00-524-0718	C-4	7
			C-5	7
			C-9	2

PART NUMBER INDEX (continued)

<u>FSCM</u>	<u>PART NUMBER</u>	<u>STOCK NUMBER</u>	<u>Figure No.</u>	<u>ITEM</u>
05476	MS 90725-64 (1, 0400)		C-7	12
05476	MS 90725-8 (1, 0403)		C-4	4
			C-5	4
05476	MS 90725-64 (1, 0400)		C-4	2
			C-5	2
05476	1, 0364		C-7	7, 8 & Group 06
05476	CFB-263-2		C-6	2
05476	90006		C-4	6
			C-5	6
05476	90005		C-4	8
			C-5	8
05476	1, 0365	4820-00-287-6041	C-8	1
05476	1, 0443		C-3	2
05476	1, 0375		C-8	2
05476	1, 0362		C-4	13
05476	1, 0402		C-5	13
			C-3	3
05476	1, 0401		C-6	3
05476	90004-2		C-6	5
05476	1, 0352	5330-00-647-2072	C-7	3
			C-9	5

APPENDIX D

COMPONENTS OF END ITEM AND BASIC ISSUE ITEMS LIST

SECTION I

INTRODUCTION

- D-1** **SCOPE.** This appendix lists all components of end item and basic issue items for the 50,000 gallon water tank to help you inventory items required for safe and efficient operation.
- D-2** **GENERAL.** The Components of End Item and Basic Issue Items Lists are divided into the following sections:
- a. Section II. Components of End Item. This listing is for informational purposes only, and is not authority to requisition replacements. These items are part of the end item, but are removed and separately packaged for transportation or shipment. As part of the end item, these items must be with the end item whenever it is issued or transferred between property accounts. Illustrations are furnished to assist you in identifying the items. Reference Appendix C this manual.
 - b. Section III. Basic Issue Items List. Not applicable.
- D-3** **EXPLANATION OF COLUMNS.** The following provides an explanation of columns found in the tabular listings:
- a. Column (1) - Illustration Number (Illus Number). This column indicates the number of the illustration in which the item is shown.
 - b. Column (2) - Identification. Indicates the part number assigned to the end item and will be used for requisitioning purposes. This includes the FSCM number and National Stock Number.

APPENDIX D (continued)

D-3 EXPLANATION OF COLUMNS (continued).

- c. Column (3) - Description. Indicates the Federal item name and, if required, a minimum description to identify and locate the item.
- d. Column (4) - Unit of Measure (U/M). Indicates the measure used in performing the actual operation/maintenance function. This measure is expressed by a two-character alphabetical abbreviation (e.g., ea, in, pr).
- e. Column (5) - Quantity Required (Qty. Rqr). Indicates the quantity of the item authorized to be used with/on the equipment.

APPENDIX D

SECTION II

COMPONENT IDENTIFICATION LIST

This appendix list and identifies components of the 50, 000 gallon drinking water (potable water) tank.

Illustration Number		Identification Number			Description	U/M	Qty. Inc. In Unit
(a) Fig. No.	(b) No. Item	Part Number	FSCM	NSN			
C-1	8				Tank, Fabric 50, 000 Collapsible	Ea.	1
C-2	1	91005	05476	5430-01-106-9677	Tank Envelope	Ea.	1
C-3	9				Vent Assembly	Ea.	1
		1, 0374	05476		Cap Relief with gasket	Ea.	1
		1, 0443	05476		Standpipe 2" NOM	Ea.	1
		MS27024-11	05476	4720-00-649-9103	Coupling, OD, Female 2"	Ea.	1
		1, 0403	05476	5305-00-225-3839	Bolt Hex Hd 1/4" x 1.25"	Ea.	8
		MS27183-10	05476	5310-00-809-4058	Washer, Flat 1/4"	Ea.	8
		MS27023-21	05476		Flange Adaptor, Coupl.	Ea.	1
		MS29513-250	05476	5330-00-291-3085	"O" Ring	Ea.	1
		MS27028-11	05476	4730-00-649-9100	Dust Cap with chain & gasket	Ea.	1
		MS27030-6	05476	5310-00-612-2414	Gasket 2"	Ea.	1
C-4	14				Filler Assembly	Ea.	1
		MS27019	05476		Cplr, Elbow with gasket	Ea.	1
		MS90725-64	05476		Bolt, Hex Hd 3/8" x 1.5"	Ea.	8
		MS27183-13	05476		Washer, Lock 3/8"	Ea.	8
		MS90725-8	05476	5305-00-225-3839	Bolt, Hex Hd 1/4" x 1.00"	Ea.	20
		MS27183-10	05476	5310-00-809-4058	Washer, Flat 1/4"	Ea.	20
		90006	05476		Closure Plate	Ea.	1
		MS90213-83	05476	5330-00-524-0718	"O" Ring	Ea.	1
		90005	05476		Suction Stud	Ea.	1
		1, 0352	05476	5330-00-647-2072	Gasket	Ea.	2
		MS27028-17	05476		Dust Cap with gasket & chain	Ea.	1
		MS27023-17	05476		Adaptor, Flanges	Ea.	1
		MS27030-9	05476		Gasket	Ea.	2
		1, 0362	05476		Washer, Thread, Seal	Ea.	8
		MS51967	05476		Nut, Hex, 3/8"	Ea.	8

APPENDIX D (Continued)

Illustration Number		Identification Number			Description	U/M	Qty. Inc. In Unit	
(a) Fig. No.	(b) No. Item	Part Number	FSCM	NSN				
C-5	14	1, 0356	05476		Discharge Assembly	Ea.	1	
		MS90725-64	05476		Cplr, Elbow w/gasket	Ea.	1	
		MS27183-13	05476		Bolt, Hex Hd, 3/8"	Ea.	8	
		MS90725-8	05476	5305-00-225-3839	Washer, Lock 3/8"	Ea.	8	
		MS27183-10	05476	5310-00-809-4058	Bolt, Hex Hd 1/4"	Ea.	20	
		90006	05476		Washer, Flat 1/4"	Ea.	20	
		MS90213-83	05476	5330-00-524-0718	Closure Plate	Ea.	1	
		90005	05476		"O" Ring	Ea.	1	
		1, 0352	05476	5330-00-637-2072	Suction Stud	Ea.	1	
		MS27028-11	05476		Gasket	Ea.	2	
		MS27023-17	05476		Dust Cap w/gasket & chain	Ea.	1	
		MS27030-9	05476		Adaptor, Flanged	Ea.	1	
		1, 0362	05476		Gasket	Ea.	1	
		MS51967	05476		Washer, Thread, Seal	Ea.	8	
					Nut, Hex Hd, 3/8"	Ea.	8	
		C-65		MS29513-250	05476	5330-00-291-3085	Drain Assembly	Ea.
CFB-263-2	05476				"O" Ring	Ea.	1	
90006-2	05476				Plug, Screw & Chain	Ea.	1	
1, 0401	05476			5305-00-225-3839	Drain Fitting	Ea.	1	
MS27183-10	05476			5310-00-809-4058	Bolt, Hex Hd, 1/4"	Ea.	1	
					Washer, Flat	Ea.	8	
C-7	12	1, 0364	05476		*Valve Assembly 4"	Ea.	1	
		MS27028-17	05476		Dust Cap w/gasket & cable	Ea.	1	
		MS27023-17	05476		Cplr Half, OD, Male	Ea.	1	
		Flanged						
		1, 0352	05476	5330-00-642-2072	Gasket	Ea.	2	
		MIL-V-58039	81349		Gate Valve 4" Type I	Ea.	1	
		MS27027-17	96906		Cplr Half, OD, Female	Ea.	1	
		Flanged						
		MS27030-9	05476		Gasket	Ea.	2	
		MS27029-17	05476		*Dust Plug w/chain	Ea.	1	
					Type II, Class 3			
MS51967	05476		Nut Hex 3/8"	Ea.	16			
MS27183-13	05476	5310-00-637-9541	Washer Lock 3/8"	Ea.	16			
1, 0572	05476		Washer, Flat 3/8"	Ea.	16			
MS90725-64	05476		Bolt, Hex Hd 3/4" x 1.5"	Ea.	16			

*Complete Assembly

APPENDIX D (Continued)

Illustration Number		Identification Number			Description	U/M	Qty. Inc. In Unit
(a) Fig. No.	(b) No. Item	Part Number	FSCM	NSN			
C-8	2	1, 0365	05476	5330-00-287-6041	Hoses	Ea.	1
					Valve, 1/2"	Ea.	1
		1, 0375	05476		Hose Assembly, 3/4" x 8' ZZ-H-601G3 Class II	Ea.	1
C-9	6	MS29513-250	05476	5330-00-291-3085	Emergency Repair Items	Ea.	1
		MS90213-83	05476	5330-00-524-0718	"O" Ring	Ea.	2
		MS27030-6	05476		"O" Ring	Ea.	2
		MS27030-9	05476		Gasket, Flange	Ea.	2
		1, 0352	05476	5330-00-647-2072	Gasket, Flange	Ea.	2
		TBD	05476	5430-00-641-8957	Gasket, 4" Flange	Ea.	2
C-10	5				Emergency Repair Kit	Ea.	1
		1, 0139	05476	5430-00-591-6863	Emergency Repair Kit Items	Ea.	1
		1, 0140	05476	5430-00-591-6864	Clamp, Sealing 3"	Ea.	4
		1, 0141	05476	5430-00-591-6865	Clamp, Sealing 5"	Ea.	2
		1, 0430	05476	5510-00-255-9493	Clamp, Sealing 7-1/2"	Ea.	2
		1, 0431	05476	5510-00-255-9692	Plug, Tapered, 3"	Ea.	2
				Plug, Tapered, 5"	Ea.	2	

APPENDIX E

EXPENDABLE/DURABLE SUPPLIES AND MATERIALS LIST

Section 1. INTRODUCTION

E-1 **Scope.** This listing is for information purposes only and is not authority to requisition the listed items These items are authorized to you by CTA 50-970, Expendable/Durable Items (except medical, class V, repair parts, and heraldic items)

E-2 **Explanation of Columns.**

a Column (1) - Item Number. This number is assigned to the entry in the listing and is referenced in the narrative instructions to identify the material (e g , Use cleaning compound, item 5, appendix C)

b Column (2)-Level This column identifies the lowest level of maintenance that requires the listed item.

- C - Operator/Crew
- 0 - Unit Maintenance
- F - Direct Support Maintenance
- H - General Support Maintenance

c Column (3)-National Stock Number This is the National Stock Number assigned to the item, use it to request or requisition the item

d Column (4)-Description Indicates the Federal item name, and, if required, a description to identify the item The last line for each item indicates the Commercial and Government Entity Code (CAGEC) in parentheses followed by the part number

e Column (5) - Unit of Measure (U/M) Indicates the measure used in performing the actual maintenance function. This measure is expressed by a two- character alphabetical abbreviation (e g , EA, IN, PR) If the unit of measure differs from the unit of issue, requisition the lowest unit of issue that will satisfy your requirements

Section 11. EXPENDABLE/DURABLE SUPPLIES AND MATERIALS LIST

(1) Item National	(2) Level	(3) National Stock Number	(4) Description	(5) U/M
	0	8030-00-889-3535	TAPE, ANTISEIZER	

*U.S. GOVERNMENT PRINTING OFFICE 1992 654-028/60388

By Order of the Secretary of the Army

Official

R. L. DILWORTH
Brigadier General, United States Army
The Adjutant General

JOHN A. WICKHAM, JR
General, United States Army
Chief of Staff

DISTRIBUTION:

To be distributed in accordance with DA Form 12-25A, Operator, Organizational and Direct Support Maintenance requirements for Tank, Fabric, Collapsible, POL, 50, 000, 10, 000, 3, 000 GAL.

The Metric System and Equivalents

Linear Measure

1 centimeter = 10 millimeters = .39 inch
 1 decimeter = 10 centimeters = 3.94 inches
 1 meter = 10 decimeters = 39.37 inches
 1 dekameter = 10 meters = 32.8 feet
 1 hectometer = 10 dekameters = 328.08 feet
 1 kilometer = 10 hectometers = 3,280.8 feet

Weights

1 centigram = 10 milligrams = .15 grain
 1 decigram = 10 centigrams = 1.54 grains
 1 gram = 10 decigrams = .035 ounce
 1 dekagram = 10 grams = .35 ounce
 1 hectogram = 10 dekagrams = 3.52 ounces
 1 kilogram = 10 hectograms = 2.2 pounds
 1 quintal = 100 kilograms = 220.46 pounds
 1 metric ton = 10 quintals = 1.1 short tons

Liquid Measure

1 centiliter = 10 milliliters = .34 fl. ounce
 1 deciliter = 10 centiliters = 3.38 fl. ounces
 1 liter = 10 deciliters = 33.81 fl. ounces
 1 dekaliter = 10 liters = 2.64 gallons
 1 hectoliter = 10 dekaliters = 26.42 gallons
 1 kiloliter = 10 hectoliters = 264.18 gallons

Square Measure

1 sq. centimeter = 100 sq. millimeters = .155 sq. inch
 1 sq. decimeter = 100 sq. centimeters = 15.5 sq. inches
 1 sq. meter (centare) = 100 sq. decimeters = 10.76 sq. feet
 1 sq. dekameter (are) = 100 sq. meters = 1,076.4 sq. feet
 1 sq. hectometer (hectare) = 100 sq. dekameters = 2.47 acres
 1 sq. kilometer = 100 sq. hectometers = .386 sq. mile

Cubic Measure

1 cu. centimeter = 1000 cu. millimeters = .06 cu. inch
 1 cu. decimeter = 1000 cu. centimeters = 61.02 cu. inches
 1 cu. meter = 1000 cu. decimeters = 35.31 cu. feet

Approximate Conversion Factors

To change	To	Multiply by	To change	To	Multiply by
inches	centimeters	2.540	ounce-inches	newton-meters	.007062
feet	meters	.305	centimeters	inches	.394
yards	meters	.914	meters	feet	3.280
miles	kilometers	1.609	meters	yards	1.094
square inches	square centimeters	6.451	kilometers	miles	.621
square feet	square meters	.093	square centimeters	square inches	.155
square yards	square meters	.836	square meters	square feet	10.764
square miles	square kilometers	2.590	square meters	square yards	1.196
acres	square hectometers	.405	square kilometers	square miles	.386
cubic feet	cubic meters	.028	square hectometers	acres	2.471
cubic yards	cubic meters	.765	cubic meters	cubic feet	35.315
fluid ounces	milliliters	29.573	cubic meters	cubic yards	1.308
pints	liters	.473	milliliters	fluid ounces	.034
quarts	liters	.946	liters	pints	2.113
gallons	liters	3.785	liters	quarts	1.057
ounces	grams	28.349	liters	gallons	.264
pounds	kilograms	.454	grams	ounces	.035
short tons	metric tons	.907	kilograms	pounds	2.205
pound-feet	newton-meters	1.356	metric tons	short tons	1.102
pound-inches	newton-meters	.11296			

Temperature (Exact)

°F	Fahrenheit temperature	5/9 (after subtracting 32)	Celsius temperature	°C
----	------------------------	----------------------------	---------------------	----

RECOMMENDED CHANGES TO EQUIPMENT TECHNICAL PUBLICATIONS



THEN... JOT DOWN THE DOPE ABOUT IT ON THIS FORM, CAREFULLY TEAR IT OUT, FOLD IT AND DROP IT IN THE MAIL!

SOMETHING WRONG WITH THIS PUBLICATION?

FROM: (PRINT YOUR UNIT'S COMPLETE ADDRESS)

DATE SENT

PUBLICATION NUMBER

PUBLICATION DATE

PUBLICATION TITLE

BE EXACT... PIN-POINT WHERE IT IS

PAGE NO.

PARA-GRAPH

FIGURE NO.

TABLE NO.

IN THIS SPACE TELL WHAT IS WRONG AND WHAT SHOULD BE DONE ABOUT IT:

TEAR ALONG PERFORATED LINE

PRINTED NAME, GRADE OR TITLE, AND TELEPHONE NUMBER

SIGN HERE:

DA FORM 2028-2 JUL 79

PREVIOUS EDITIONS ARE OBSOLETE.

P.S.—IF YOUR OUTFIT WANTS TO KNOW ABOUT YOUR RECOMMENDATION MAKE A CARBON COPY OF THIS AND GIVE IT TO YOUR HEADQUARTERS.

